

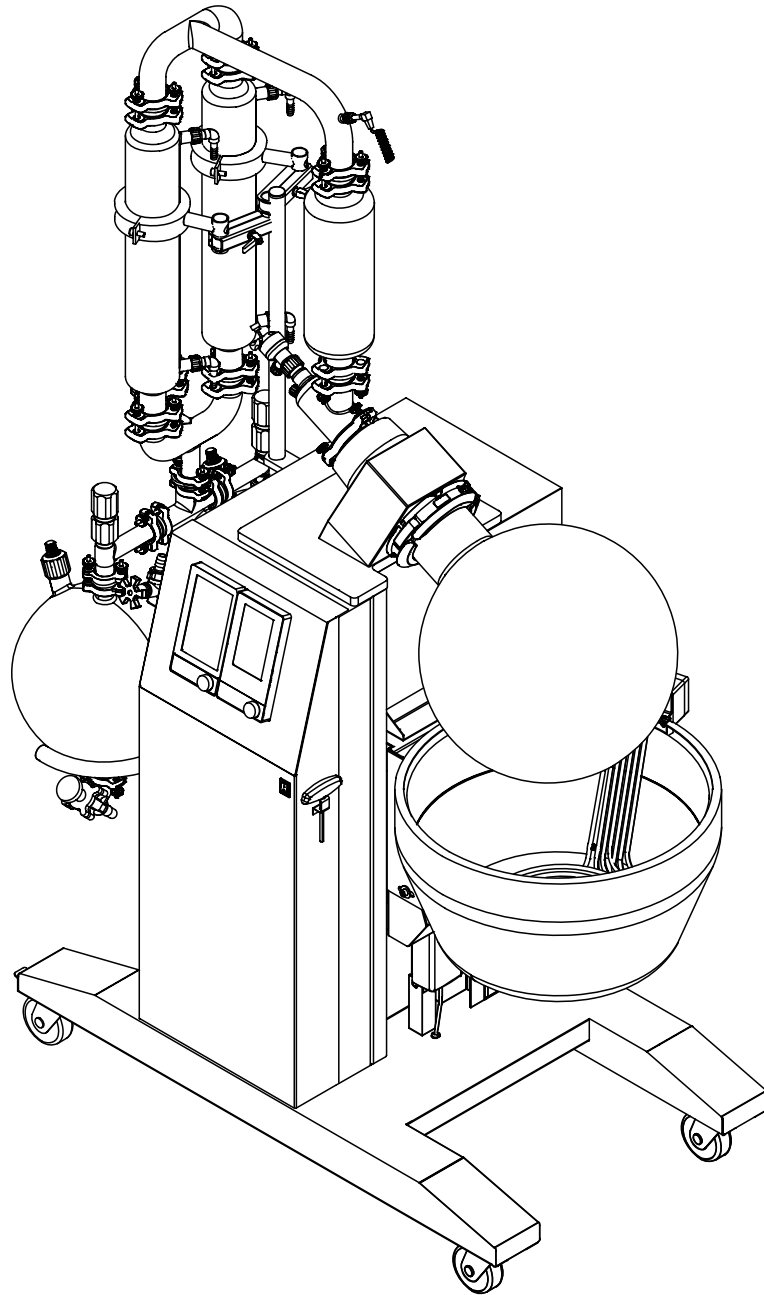

# Rotavapor® R-250 Pro

## Operation Manual



## **Imprint**

Product Identification:

Operation Manual (Original) Rotavapor® R-250 Pro  
11594225

Publication date: 03.2022

Version B

BÜCHI Labortechnik AG

Meierseggstrasse 40

Postfach

CH-9230 Flawil 1

E-Mail: [quality@buchi.com](mailto:quality@buchi.com)

BUCHI reserves the right to make changes to the manual as deemed necessary in the light of experience, especially with respect to structure, illustrations and technical details.

This manual is copyrighted. Information from it may neither be reproduced, distributed, or used for competitive purposes, nor made available to third parties. The manufacture of any component with the aid of this manual without prior written agreement is also prohibited.

## Table of contents

<b>1</b>	<b>About this document.....</b>	<b>6</b>
1.1	Mark-ups and symbols .....	6
1.2	Trademarks .....	6
1.3	Connected devices .....	6
<b>2</b>	<b>Safety .....</b>	<b>7</b>
2.1	Proper use .....	7
2.2	Use other than intended .....	7
2.3	Staff qualification .....	7
2.4	Personal protective equipment .....	8
2.5	Warning notices in this document.....	8
2.6	Warning symbols .....	9
2.7	Residual risks .....	9
	2.7.1 Dangerous vapors .....	10
	2.7.2 High internal pressure .....	10
	2.7.3 Hot surfaces and liquids .....	10
	2.7.4 Rotating parts .....	10
	2.7.5 Faults during operation.....	10
	2.7.6 Glass breakage .....	10
2.8	Modifications.....	11
<b>3</b>	<b>Product description.....</b>	<b>12</b>
3.1	Description of function .....	12
3.2	Configuration .....	13
	3.2.1 Front view .....	13
	3.2.2 Rear view.....	14
	3.2.3 Connections on the rear side.....	15
3.3	Scope of delivery .....	16
3.4	Type plate .....	16
3.5	Technical data .....	17
	3.5.1 Rotavapor® R-250Pro .....	17
	3.5.2 Ambient conditions .....	18
	3.5.3 Materials .....	18
	3.5.4 Installation site.....	18
<b>4</b>	<b>Transport and storage .....</b>	<b>19</b>
4.1	Storage .....	19
4.2	Transport .....	19
4.3	Moving the instrument .....	19
4.4	Installing and removing the transportation lock .....	19

<b>5</b>	<b>Installation.....</b>	<b>21</b>
5.1	Before installation .....	21
5.2	Establishing electrical connections .....	21
5.3	Installing the support rod .....	21
5.4	Installing the glassware .....	22
5.4.1	Glassware assembling instructions .....	22
5.4.2	Installing the inlet valve (example) .....	24
5.4.3	Installing the distribution piece (example) .....	24
5.4.4	Installing the glass assembly R (option) .....	25
5.4.5	Installing the glass assembly D (option) .....	26
5.4.6	Installing the double receiver .....	27
5.4.7	Installing the single receiver (option) .....	28
5.4.8	Connecting the receiver with the glass assembly (example) .....	28
5.5	Installing the vacuum supply .....	29
5.5.1	Installing the vacuum pump holder (option) .....	29
5.5.2	Installing a BUCHI vacuum pump (option) .....	29
5.5.3	Installing a non BUCHI vacuum pump (option) .....	30
5.5.4	Installing the vacuum connection glass assembly R (option) .....	30
5.5.5	Installing the vacuum connection glass assembly D (option) .....	32
5.6	Installing the cooling water supply .....	33
5.6.1	Installing the cooling water supply with a recirculating chiller (option) .....	33
5.6.2	Installing the cooling water supply without a recirculating chiller (option) .....	34
5.7	Heating bath installations .....	35
5.7.1	Installing the splash protection (option) .....	35
5.7.2	Installing the heating bath replenishment (option) .....	36
5.7.3	Installing the drain connection at the heating bath .....	36
5.7.4	Setting the heating bath reaction during a power interruption .....	36
5.8	Installing the sensors .....	37
5.8.1	Installing the vapor temperature sensor .....	37
5.8.2	Installing the cooling temperature sensor (option) .....	37
5.8.3	Installing the foam sensor (option) .....	38
5.8.4	Installing the cooling water flow sensor (option) .....	38
5.8.5	Installing the level sensor (option) .....	39
5.8.6	Setting up the sensors .....	39
5.9	Preparing the instrument for remote control (option) .....	40
<b>6</b>	<b>Layout of the interface .....</b>	<b>42</b>
<b>7</b>	<b>Preparing for an evaporation .....</b>	<b>43</b>
7.1	Installing and removing the evaporation flask .....	43
7.2	Operating the inlet valve .....	44
7.3	Preparing the heating bath .....	44
7.4	Draining distillate .....	45
7.5	Operating the splash protection .....	45
<b>8</b>	<b>Carrying out an evaporation.....</b>	<b>47</b>
8.1	Preparing the instrument .....	47
8.2	Starting an evaporation .....	47
8.3	Task during an evaporation .....	47
8.4	Ending an evaporation .....	47
8.5	Shutting down the instrument .....	48

<b>9</b>	<b>Cleaning and servicing .....</b>	<b>49</b>
9.1	Regular maintenance work .....	49
9.2	Replacing the vacuum seal .....	49
9.3	Replacing the evaporation flask seal .....	50
9.4	Installing the vapor duct .....	50
9.5	Setting max. heating bath temperature .....	51
<b>10</b>	<b>Help with faults .....</b>	<b>52</b>
10.1	Troubleshooting .....	52
10.2	Error messages .....	52
10.3	Resetting the overtemperature protection .....	56
10.4	Replacing the inlet valve plunger .....	56
10.5	Adjusting the cooling water flow sensor .....	57
10.6	Adjusting the level sensor .....	57
10.7	Adjusting the foam sensor .....	57
<b>11</b>	<b>Taking out of service and disposal .....</b>	<b>59</b>
11.1	Taking out of service .....	59
11.2	Disposal .....	59
11.3	Returning the instrument .....	59
<b>12</b>	<b>Appendix .....</b>	<b>60</b>
12.1	Schematics .....	60
	12.1.1 Vacuum .....	60
	12.1.2 Cooling water circuit .....	60
12.2	Spare parts and accessories .....	61
	12.2.1 Spare parts glass ware .....	61
	12.2.2 Further spare parts .....	72
	12.2.3 Inlet valve .....	73
	12.2.4 Accessories .....	74
	12.2.5 Hoses .....	76
	12.2.6 Gear box .....	77

# 1 About this document

This operation manual is applicable for all variants of the instrument. Read this operation manual before operating the instrument and follow the instructions to ensure safe and trouble-free operation. Keep this operation manual for later use and pass it on to any subsequent user or owner.

BÜCHI Labortechnik AG accepts no liability for damage, faults and malfunctions resulting from not following this operation manual.

If you have any questions after reading this operation manual:

- ▶ Contact BÜCHI Labortechnik AG Customer Service.

<https://www.buchi.com/contact>

## 1.1 Mark-ups and symbols



### NOTE

This symbol draws attention to useful and important information.

- ☑ This character draws attention to a requirement that must be met before the instructions below are carried out.
- ▶ This character indicates an instruction that must be carried out by the user.
- ⇒ This character indicates the result of a correctly carried out instruction.

Mark-up	Explanation
<i>Window</i>	Software Windows are marked-up like this.
<i>Tab</i>	Tabs are marked-up like this.
<i>Dialog</i>	Dialogs are marked-up like this.
[ <i>Button</i> ]	Buttons are marked-up like this.
[ <i>Field names</i> ]	Field names are marked-up like this.
[ <i>Menu / Menu item</i> ]	Menus or menu items are marked-up like this.
<b>Status</b>	Status is marked-up like this.
<b>Signal</b>	Signals are marked-up like this.

## 1.2 Trademarks

Product names and registered or unregistered trademarks that are used in this document are used only for identification and remain the property of the owner in each case.

## 1.3 Connected devices

In addition to these operating instructions, follow the instructions and specifications in the documentation for the connected devices.

## 2 Safety

### 2.1 Proper use

The instrument is designed for rotary evaporation.

The instrument can be used in laboratories and production for the following tasks:

- Evaporating solvents
- Synthesis of chemicals
- Purification of chemicals
- Concentration of solvents
- Recycling of solvents
- Recrystallization
- Drying of powders and granulates

### 2.2 Use other than intended

The use of the instrument other than described in proper use and specified in technical data is use other than intended.

The operator is responsible for damages or hazards that are caused by use other than intended.

Specially the following uses are not permitted:

- Use of the instrument in areas which require explosion-safe instruments.
- Use of the instrument for food, pharmacy and cosmetic products without appropriate cleaning.
- Use of samples, which can explode or inflame (example: explosives, etc.) due to shock, friction, heat or spark formation.
- Use of the instrument with solvents containing peroxides.
- Use of the instrument in overpressure situations.
- Use of the instrument with other than original BUCHI glassware.
- Use of the instrument with explosive gas mixtures.
- The use of the instrument for drying hard, brittle substances that could damage the glassware.
- Use of the instrument with a heating medium with a flash point less than 200 °C.

### 2.3 Staff qualification

Unqualified persons are unable to identify risks and are therefore exposed to greater dangers.

The device may only be operated by suitably qualified laboratory staff.

These operating instructions are aimed at the following target groups:

## Users

Users are persons that meet the following criteria:

- They have been instructed in the use of the device.
- They are familiar with the contents of these operating instructions and the applicable safety regulations and apply them.
- They are able on the basis of their training or professional experience to assess the risks associated with the use of the device.

## Operator

The operator (generally the laboratory manager) is responsible for the following aspects:

- The device must be correctly installed, commissioned, operated and serviced.
- Only suitably qualified staff may be assigned the task of performing the operations described in these operating instructions.
- The staff must comply with the local applicable requirements and regulations for safe and hazard-conscious working practices.
- Safety-related incidents that occur while using the device should be reported to the manufacturer (quality@buchi.com).

## BUCHI service technicians

Service technicians authorized by BUCHI have attended special training courses and are authorized by BÜCHI Labortechnik AG to carry out special servicing and repair measures.

## 2.4 Personal protective equipment

Depending on the application, hazards due to heat and/or corrosive chemicals may arise.

- ▶ Always wear appropriate personal protective equipment such as safety goggles, protective clothing and gloves.
- ▶ Make sure that the personal protective equipment meets the requirements of the safety data sheets for all chemicals used.

## 2.5 Warning notices in this document





Warning notices warn you of dangers that can occur when handling the device. There are four danger levels, each identifiable by the signal word used.

Signal word	Meaning
DANGER	Indicates a danger with a high level of risk which could result in death or serious injury if not prevented.
WARNING	Indicates a danger with a medium level of risk which could result in death or serious injury if not prevented.
CAUTION	Indicates a danger with a low level of risk which could result in minor or medium-severity injury if not prevented.
NOTICE	Indicates a danger that could result in damage to property.



## 2.6 Warning symbols

The following warning symbols are displayed in this operation manual or on the instrument.

Symbol	Meaning
	General warning
	Device damage
	Dangerous electrical voltage
	Hot surface
	Hand injuries

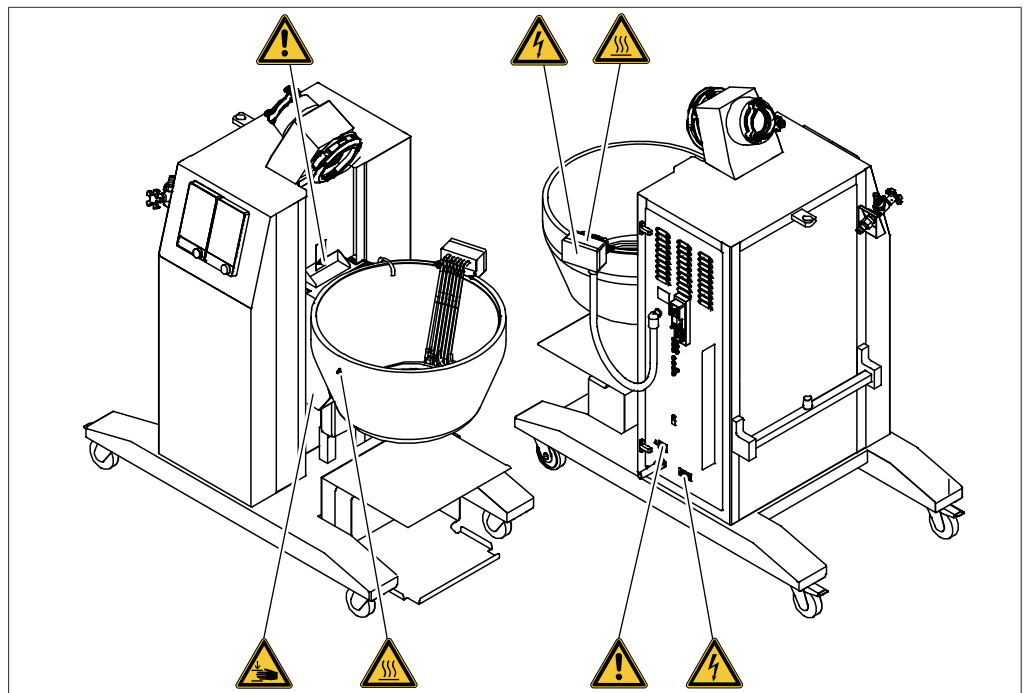

Fig. 1: Location of the warning symbols on the instrument

## 2.7 Residual risks

The device has been developed and manufactured using the latest technological advances. Nevertheless, risks to persons, property or the environment can arise if the device is used incorrectly.

Appropriate warnings in this manual serve to alert the user to these residual dangers.

### 2.7.1 Dangerous vapors

Distillation can produce dangerous vapors that are capable of causing life-threatening toxic effects.

- ▶ Do not inhale any vapors produced during distillation.
- ▶ Ensure that vapors are removed by a suitable fume hood.
- ▶ Only use the device in well ventilated areas.
- ▶ If vapors escape from joints or connections, check the seals concerned and replace them if necessary.
- ▶ Do not distill any unknown fluids.
- ▶ Observe the safety data sheets for all fluids used.

### 2.7.2 High internal pressure

The evaporation of fluids can produce high pressures inside the flask or the condenser. If that pressure becomes too great, the glass components could explode.

- ▶ Make sure that the internal pressure inside the glass components is never greater than atmospheric pressure.
- ▶ When distilling without a vacuum, set the vacuum pump to atmospheric pressure so that excess pressure is automatically dissipated.
- ▶ If a vacuum pump is not used, leave the vacuum connection open.

### 2.7.3 Hot surfaces and liquids

The heating bath, evaporating flask and parts of the condenser can become very hot. If touched they can cause skin burns.

- ▶ Do not touch hot surfaces or liquids or else wear suitable protective gloves.

### 2.7.4 Rotating parts

The evaporating flask and the vapor duct are rotated by the rotary drive unit. Hair, clothing or jewelry can become caught up if allowed to come into contact with the rotating parts.

At high speeds, the heating fluid may be sprayed out by the rotation of the evaporating flask.

- ▶ Wear work overalls or protective clothing.
- ▶ Do not wear loose or baggy items of clothing such as scarves or neck-ties.
- ▶ Tie up long hair.
- ▶ Do not wear jewelry such as necklaces or bracelets.
- ▶ At high speeds and/or high temperatures, use the optional safety guard or a similar protective arrangement.

### 2.7.5 Faults during operation

If a device is damaged, sharp edges, moving parts or exposed electrical wires can cause injuries.

- ▶ Regularly check device for visible damage.
- ▶ If faults occur, switch off the device immediately, unplug the power cord and inform the operator.
- ▶ Do not continue to use devices that are damaged.

### 2.7.6 Glass breakage

Broken glass can cause severe cuts.

Damaged glass components may implode if subjected to a vacuum.  
Minor damage to the ground joints impairs the sealing effect and may therefore diminish performance.

- ▶ Handle the flask and other glass components carefully and do not drop them.
- ▶ Always visually inspect glass components for damage every time they are to be used.
- ▶ Do not continue to use glass components that are damaged.
- ▶ Always wear protective gloves when disposing of broken glass.

## **2.8 Modifications**

Unauthorized modifications can effect safety and lead to accidents.

- ▶ Use only genuine BUCHI accessories, spare parts and consumables.
- ▶ Carry out technical changes only with prior written approval from BUCHI.
- ▶ Only allow changes to be made by BUCHI service technicians.

BUCHI accepts no liability for damage, faults and malfunctions resulting from unauthorized modifications.

## 3 Product description

### 3.1 Description of function

The instrument is a rotary evaporator with the aid of which single-stage distillation can be carried out quickly without unduly stressing the product. The basis of the process is the evaporation and condensing of solvents in a rotating evaporating flask under vacuum.

- The product is heated in the evaporating flask by the heating bath.
- The rotary drive unit evenly rotates the evaporating flask.
  - The rotation increases the surface area of the liquid which leads to an increased evaporation rate.
  - The rotation constantly mixes the product which prevents localized overheating and delayed evaporation.
- The vapor passes from the evaporating flask through the vapor duct into the cooling section.
- In the cooling section, the thermal energy of the vapor is transferred to the coolant fluid so that the vapor re-condenses.
- The resulting solvent is collected in the receiving flask and can then be reused or properly disposed of.

#### Distillation under vacuum

Distillation capacity depends on the following factors:

- Temperature of the heating bath
- Pressure in the evaporating flask
- Rotation speed of the evaporating flask
- Size of the evaporating flask

Pressure in the evaporating flask:

A low pressure (below atmospheric) reduces the boiling point of the solvent. A lower boiling point means the solvent does not have to be heated as much. Distillation under vacuum is more efficient and gentler on the product.

Vacuum control:

A stable vacuum adapted to the application prevents undesirable solvent emissions and bumping (boiling) of the product.

Heating bath temperature, coolant temperature and vapor temperature:

To ensure optimum distillation, it is important to make sure that the temperature difference between the coolant and the heating bath is at least 40 °C. The temperature of the rising vapor should be mid-way between the heating bath temperature and the coolant temperature.

## 3.2 Configuration

### 3.2.1 Front view

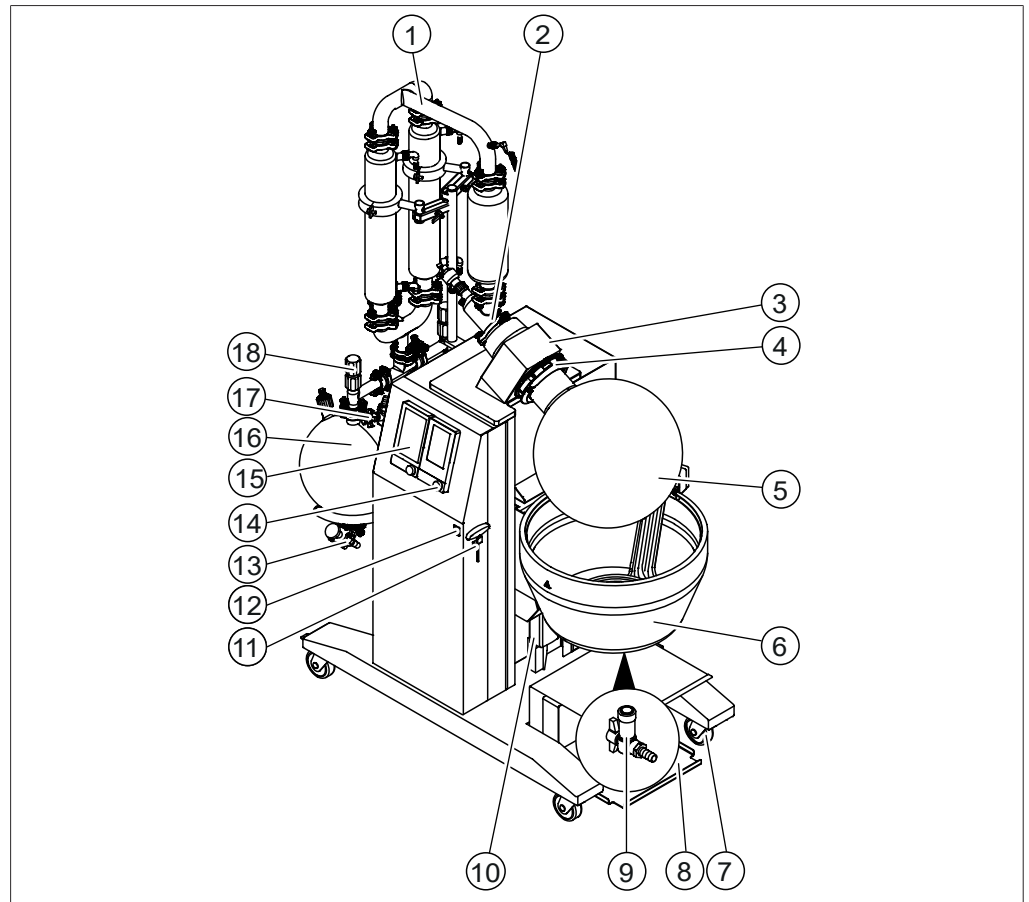

Fig. 2: Front view (example glassware)

- |  |                               |
|--|-------------------------------|
| 1 U-tube   | 2 Distribution piece          |
| 3 Gear box   | 4 Snap flange coupling        |
| 5 Evaporation flask  | 6 Heating bath                |
| 7 Castor wheels  | 8 Holder vacuum pump (option) |
| 9 Drain valve heating bath   | 10 Heating bath lift          |
| 11 Hex key for snap flange coupling                                | 12 On/Off master switch       |
| 13 Drain valve receiver  | 14 Interface                  |
| 15 Interface Pro<br>(see "Operation Manual Interface<br>I-300Pro") | 16 Receiver flask             |
| 17 Cooling water tap   | 18 Shut off tap               |

### 3.2.2 Rear view

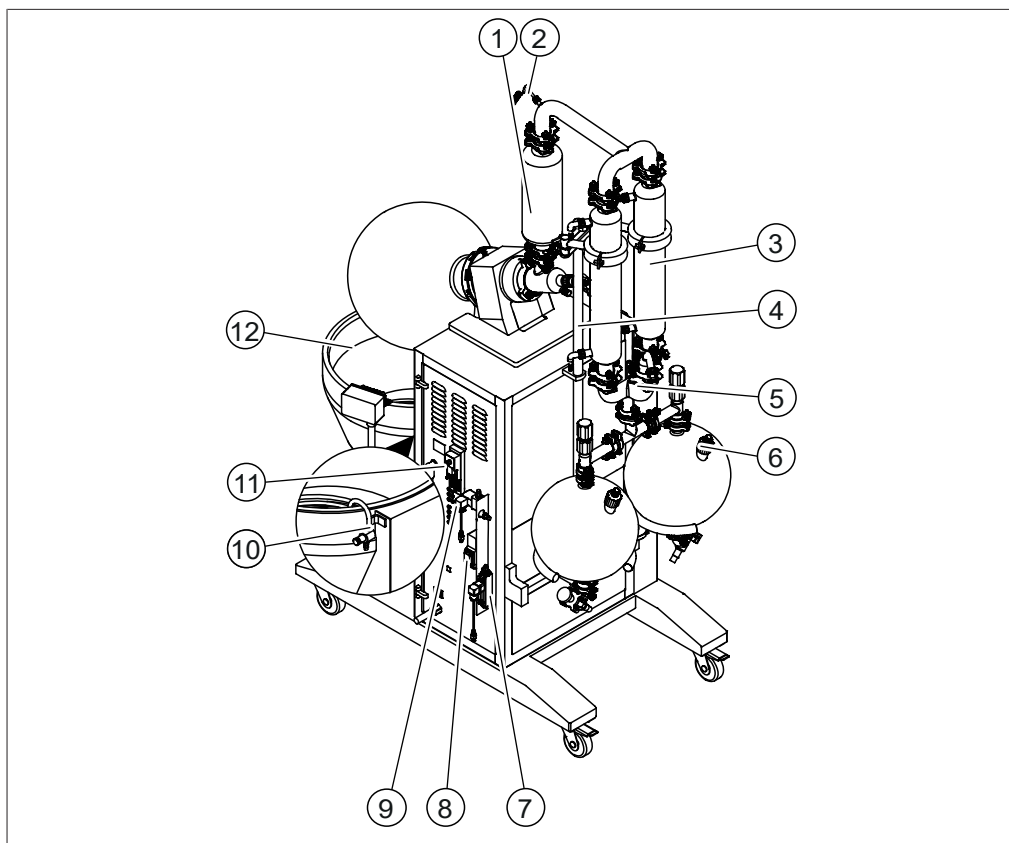

Fig. 3: Rear view (example glassware)

- |    |   |    |  |
|----|---|----|--|
| 1  | Expansion vessel  | 2  | Vapor temperature sensor                     |
| 3  | Condenser   | 4  | Support rod                                  |
| 5  | Yoke  | 6  | Receiver aeration valve                      |
| 7  | Cooling water flow sensor<br>(option)   | 8  | Vacuum valve<br>(option)                     |
| 9  | Aeration valve  | 10 | Heating bath replenishment                   |
| 11 | Connections on the rear side.<br>See Chapter 3.2.3 "Connections on<br>the rear side", page 15 | 12 | Notch<br>(max. filling level heating medium) |

### 3.2.3 Connections on the rear side



#### NOTE

If possible, do not use the VacuBox to connect the peripherals.

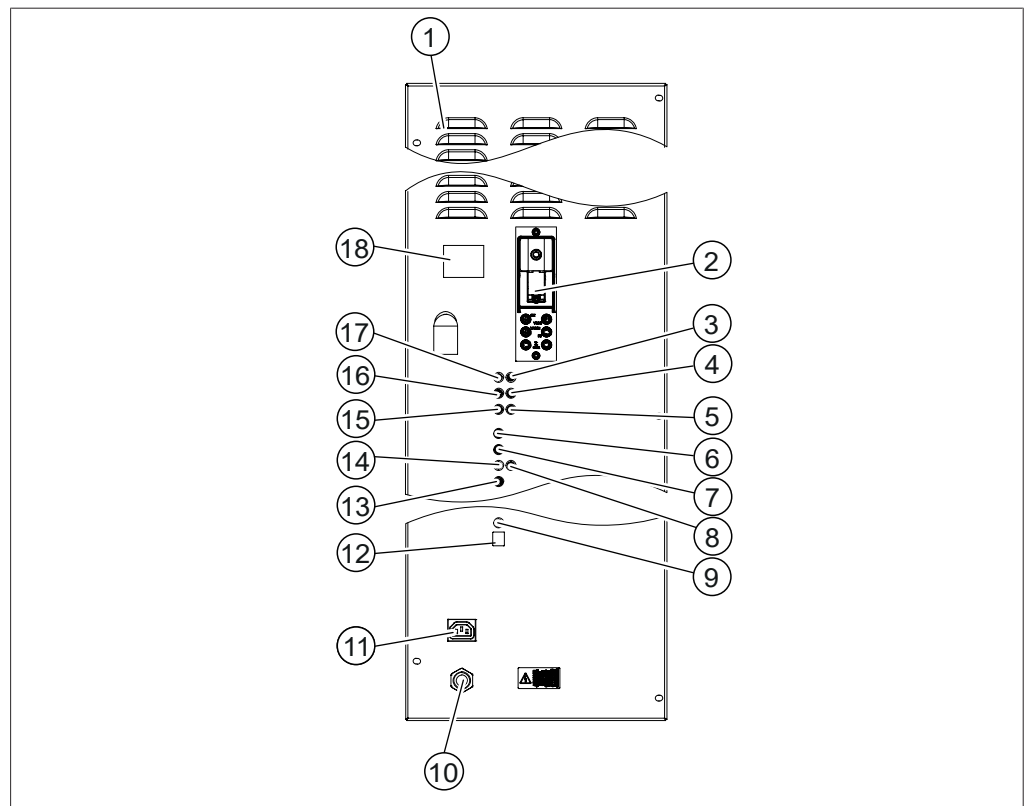

Fig. 4: Connections on the rear side

- |    |   |    |  |
|----|---|----|--|
| 1  | Ventilation slots   | 2  | VacuBox<br>(see "Operation Manual Interface I-300Pro")   |
| 3  | Cooling water temperature<br>(marked <b>CW TEMP.</b> )  | 4  | Level sensor 2<br>(marked <b>LEVEL 2</b> )   |
| 5  | Reserve<br>(marked <b>R /SERVE INPUT</b> )  | 6  | BUCHI standard communication port<br>(COM)(option for BUCHI vacuum pump)<br>(marked <b>COM</b> ) |
| 7  | BUCHI standard communication port<br>(COM) (option for BUCHI vacuum pump)<br>(marked <b>COM</b> ) | 8  | Cooling water valve<br>(marked <b>CW VALVE</b> )   |
| 9  | Foam sensor<br>(marked <b>FOAM DET.</b> )   | 10 | Power supply   |
| 11 | Power supply for connected instruments  | 12 | LAN connection<br>(marked <b>LAN</b> )   |

- |   |   |
|---|---|
| 13 Vacuum valve (non BUCHI vacuum pump only)<br>(marked <b>VACUUM VALVE</b> ) | 14 Aeration valve<br>(marked <b>AERATE</b> )                |
| 15 Cooling water flow sensor<br>(marked <b>CW FLOW</b> )                      | 16 Level sensor 1<br>(marked <b>LEVEL 1</b> )               |
| 17 Vapor temperature sensor<br>(marked <b>VAPOR TEMP.</b> )                   | 18 Type plate<br>(see Chapter 3.4 "Type plate",<br>page 16) |

### 3.3 Scope of delivery



#### NOTE

The scope of delivery depends of the configuration of the purchase order.

Accessories are delivered as per the purchase order, order confirmation, and delivery note.

### 3.4 Type plate

The type plate identifies the instrument. The type plate is located at the rear of the instrument. See Chapter 3.2.3 "Connections on the rear side", page 15

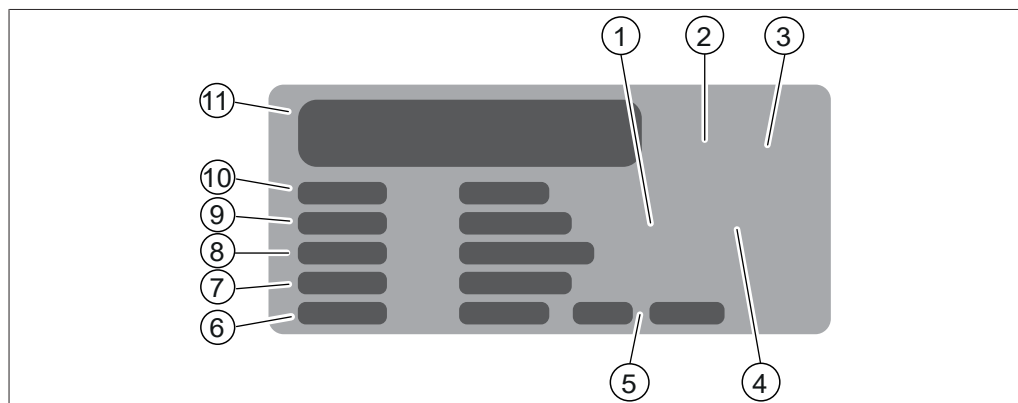

Fig. 5: Type plate

- |                                      |   |
|--------------------------------------|---|
| 1 Symbol for "electronics recycling" | 2 Initial product code                              |
| 3 Approvals                          | 4 Symbol for "Do not dispose of as household waste" |
| 5 Year of manufacture                | 6 Power consumption maximum                         |
| 7 Frequency                          | 8 Input voltage range                               |
| 9 Serial number                      | 10 Instrument name                                  |
| 11 Company name and address          |   |



### 3.5 Technical data

#### 3.5.1 Rotavapor® R-250Pro

Dimensions (W x D x H) (without glass)	1420 x 850 x 1550 mm
Dimensions (W x D x H) (with glass)	1450 x 850 x 2300 mm
Minimum clearance on all sides	400 mm
Weight (without glass)	160 kg
Weight (with glass)	200 kg
Connection voltage	400 ± 10 % VAC 3N~
Power consumption	7500 W
Frequency	50 / 60 Hz
IP Code	IP20
Pollution degree	2
Overvoltage category	II
Pump outlet	max. 2 A
Rotation speed range	5 – 120 rpm
Heating bath temperature range	20 - 180 °C ± 2 °C
Adjustment accuracy	± 1 °C
Regulation precision	At 60 °C: ± 1 °C At 95 °C: ± 2 °C At 180 °C: ± 3 °C
Heating medium	Water Polyethylene glycol 400
Minimum flashpoint of the heating oil	205 °C
Cooling water consumption	200 - 400 L/h
Vacuum pump requirement	min 3 m <sup>3</sup> / h
Leakage of the complete system	<1 mbar/min
Approval (400 VAC Connection Voltage)	CE UL / CSA
Rotation controlling	Electronically
Rotation accuracy	± 1 rpm at 5 rpm to ± 5 rpm at 120 rpm
Cooling restriction abs. without pulsation	max. 2.7 bar
Heating capacity	6600 W

### 3.5.2 Ambient conditions

For indoor use only.

Max. altitude above sea level	2000 m
Ambient and storage temperature	5 – 40 °C
Maximum relative humidity	80% for temperatures up to 31 °C decreasing linearly to 50 % relative humidity at 40 °C

### 3.5.3 Materials

Housing	Stainless steel 1.4301 (AISI 304)
Gear head	Aluminum cast (3.2373)
Painting	Powder coated with Epoxy (EPX)
Bath pan	Stainless steel 1.4404 (AISI 316L)
Heating element	Stainless steel 1.4404 (AISI 316L)
Glass	Borosilicate 3.3
In contact with product	FDA approved materials

### 3.5.4 Installation site

- The installation site has a firm, level surface.
- The installation site meets the requirements for the connected devices. See related documentation
- The installation site meets the safety requirements. See Chapter 2 "Safety", page 7
- The installation site meets the specifications according to the technical data (e.g. weight, dimension, etc.). See Chapter 3.5 "Technical data", page 17
- The installation site is not exposed to external thermal loads, such as direct solar radiation.
- The installation site has no obstacles (e.g. water taps, drains, etc.).
- The installation site has enough space that cables / tubes can be routed safely.
- The installation site allows that the power supply can be disconnected at any time in an emergency.
- The installation site meets IEC / EN 61326-1 for industrial and basic electromagnetic environments.
- The installation site has a power supply with line system impedance  $Z_{max}$  of 0.27 + j0.17 Ohms or less to which the instrument is connected.

## 4 Transport and storage

### 4.1 Storage

- ▶ Remove the heating bath medium.
- ▶ Remove the cooling water from the condensers.
- ▶ Make sure that the ambient conditions obey the technical data. See Chapter 3.5 "Technical data", page 17.
- ▶ Store the instrument in its original packaging.
- ▶ After storage, check the instrument, all glass components, seals and tubing for damage and replace if necessary.

### 4.2 Transport



#### NOTICE

##### Risk of breakage due to incorrect transportation

- ▶ Make sure that the device is fully dismantled and all parts of the device are safely packed in such a way as to prevent breakage, ideally in the original box.
  - ▶ Avoid sharp movements during transit.
- 
- ▶ After transportation, check the device and all glass components for damage.
  - ▶ Damage that has occurred in transit should be reported to the carrier.
  - ▶ Keep packing for future transportation.

### 4.3 Moving the instrument

- ▶ Release the castor breaks.
- ▶ Move the instrument to the designated place.

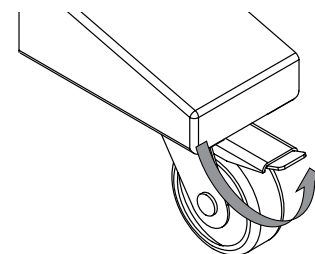

- ▶ Lock the castor breaks.

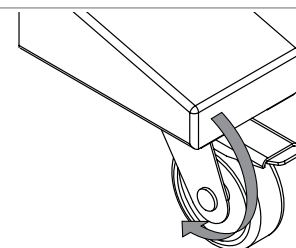

### 4.4 Installing and removing the transportation lock



#### NOTE

Installing is done in reverse sequence.

- ▶ Loosen the transportation lock screws.

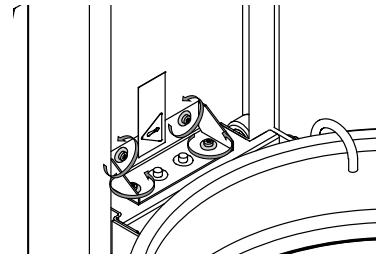

- ▶ Remove the transportation lock.

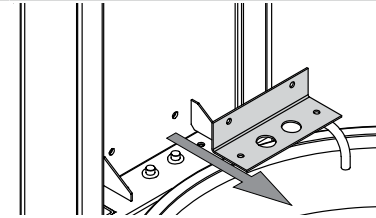

## 5 Installation

### 5.1 Before installation



#### NOTICE

##### Instrument damage due to switching it on too early.

Switching on the instrument too early after transportation can cause damage.

- ▶ Climatize the instrument after transportation.

### 5.2 Establishing electrical connections



#### WARNING

##### Death or serious burns by electric current.

- ▶ Have the installation carried out by an electrician or a person with similar expert knowledge.
- ▶ After installation, check electrical safety.

The instrument is design for stationary installation.

Precondition:

- The electrical installation is as specified in the technical data. See Chapter 3.5 "Technical data", page 17
- The installation site is as specified in the technical date. See Chapter 3.5 "Technical data", page 17
- ▶ Have the installation carried out by an electrician or a person with similar expert knowledge.
- ▶ Carry out the installation according to the instructions. See "*Guide for electrical installation*"

### 5.3 Installing the support rod

- ▶ Attach the support rod to the instrument.

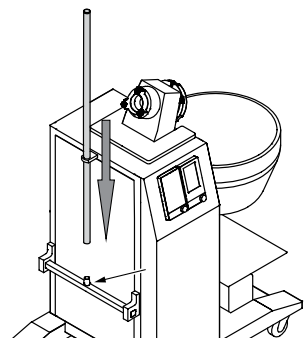

- ▶ Secure the support rod in place with a headless screw.

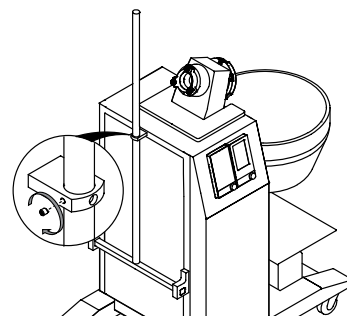

## 5.4 Installing the glassware



### NOTE

Glassware is delivered as per the purchase order, order confirmation and delivery note.

### 5.4.1 Glassware assembling instructions

#### Assembling instruction EasyClamp DN40

- ▶ Attach the two glass pieces.

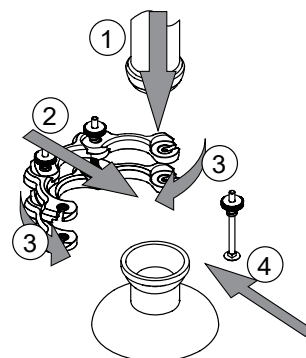

- ▶ Secure the connection in place with the easy clamp.

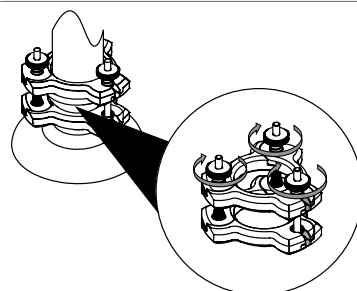

#### Assembling instruction EasyClamp DN25

- ▶ Attach the two glass pieces.

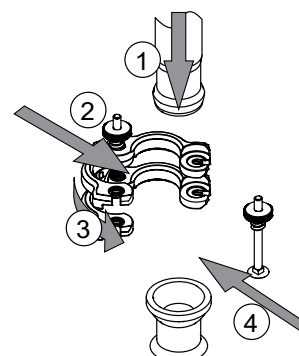

- ▶ Secure the connection in place with the easy clamp.

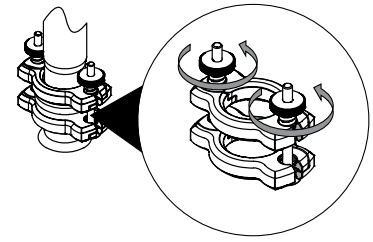

### Assembling instruction glass bracket

- ▶ Attach the glass bracket to the condenser.

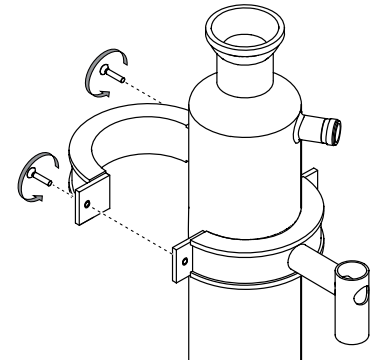

### Assembling instruction bracket

- ▶ Attach the expansion vessel to the distribution piece.

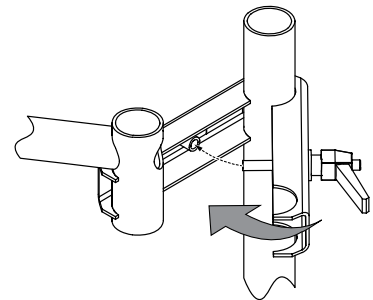

- ▶ Secure the expansion vessel in place with the easy clamp.

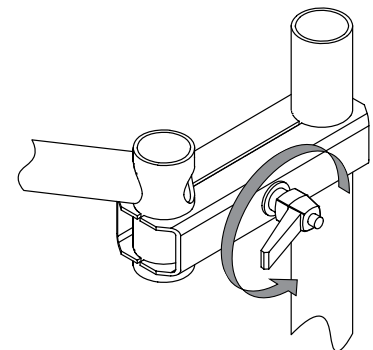

### Assembling instruction receiving vessel support

- ▶ Put the receiving vessel support on the instrument.

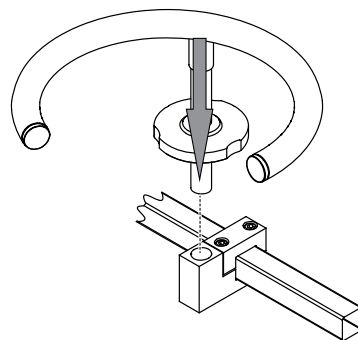

### Assembling instruction shut off tap

**NOTICE!** Tighten the shut off tap with your hands.

- ▶ Attach the shut off tap to the glassware using the white handle.

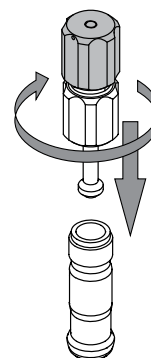

### 5.4.2 Installing the inlet valve (example)

- ▶ Attach the inlet valve to the distribution piece.

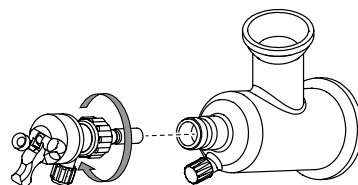

### 5.4.3 Installing the distribution piece (example)

- ▶ Attach the distribution piece to the gear box.
- ▶ Close the easy clamps.

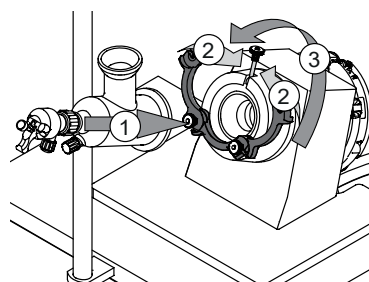

- ▶ Secure the distribution piece in place.

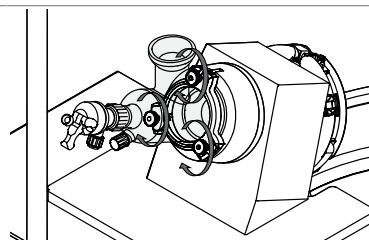



### 5.4.4 Installing the glass assembly R (option)

Installation order:

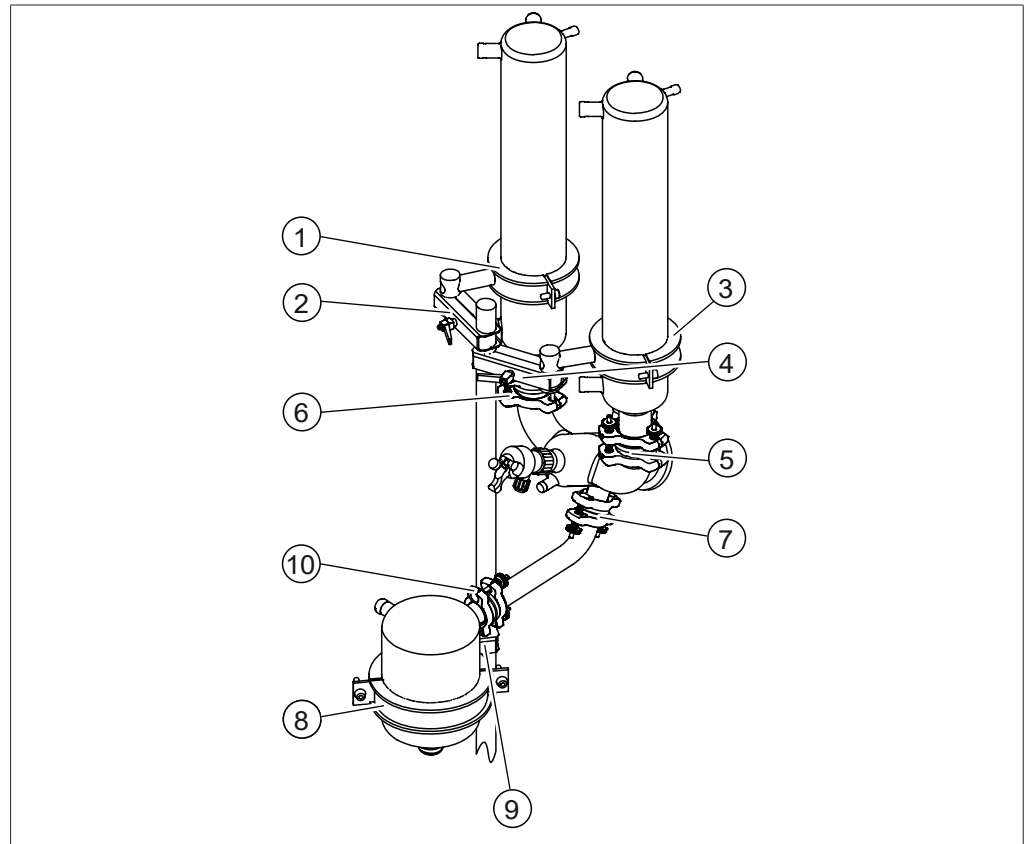

Fig. 6: Installation order Condenser R

- |   |  |    |  |
|---|--|----|--|
| 1 | See Chapter "Assembling instruction glass bracket", page 23  | 2  | See Chapter "Assembling instruction bracket", page 23        |
| 3 | See Chapter "Assembling instruction glass bracket", page 23  | 4  | See Chapter "Assembling instruction bracket", page 23        |
| 5 | See Chapter "Assembling instruction EasyClamp DN40", page 22 | 6  | See Chapter "Assembling instruction EasyClamp DN40", page 22 |
| 7 | See Chapter "Assembling instruction EasyClamp DN25", page 22 | 8  | See Chapter "Assembling instruction glass bracket", page 23  |
| 9 | See Chapter "Assembling instruction bracket", page 23        | 10 | See Chapter "Assembling instruction EasyClamp DN25", page 22 |

### 5.4.5 Installing the glass assembly D (option)

Installation order:

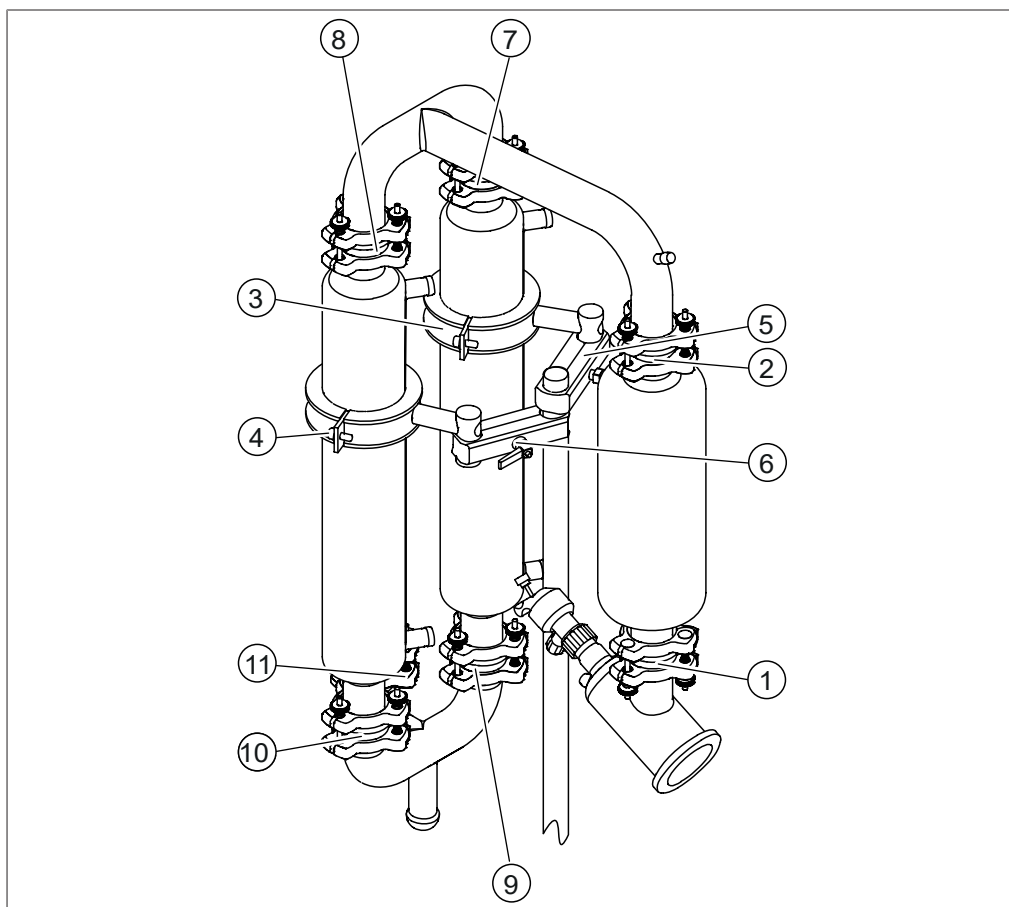

Fig. 7: Installation order glass assembly D

- |    |  |    |  |
|----|--|----|--|
| 1  | See Chapter "Assembling instruction EasyClamp DN40", page 22 | 2  | See Chapter "Assembling instruction EasyClamp DN40", page 22 |
| 3  | See Chapter "Assembling instruction glass bracket", page 23  | 4  | See Chapter "Assembling instruction glass bracket", page 23  |
| 5  | See Chapter "Assembling instruction bracket", page 23        | 6  | See Chapter "Assembling instruction bracket", page 23        |
| 7  | See Chapter "Assembling instruction EasyClamp DN40", page 22 | 8  | See Chapter "Assembling instruction EasyClamp DN40", page 22 |
| 9  | See Chapter "Assembling instruction EasyClamp DN40", page 22 | 10 | See Chapter "Assembling instruction EasyClamp DN40", page 22 |
| 11 | See Chapter "Assembling instruction EasyClamp DN40", page 22 |    |  |

### 5.4.6 Installing the double receiver

Installation order:

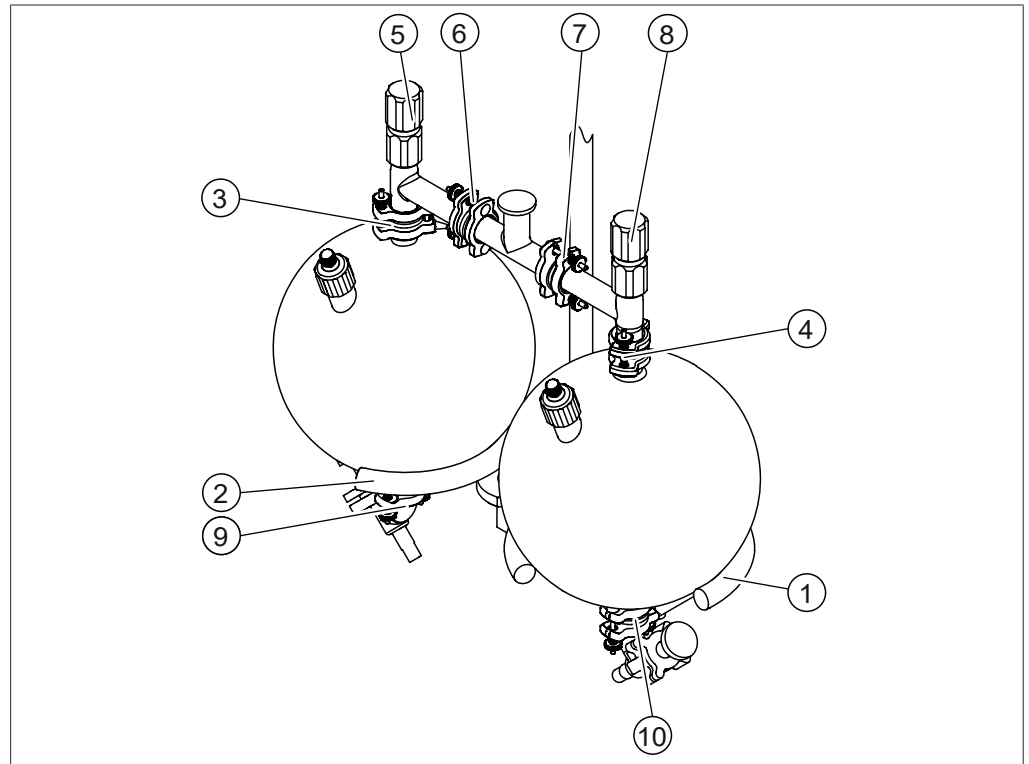

Fig. 8: Installation order double receiver

- |   |  |    |  |
|---|--|----|--|
| 1 | See Chapter "Assembling instruction receiving vessel support", page 24 | 2  | See Chapter "Assembling instruction receiving vessel support", page 24 |
| 3 | See Chapter "Assembling instruction EasyClamp DN25", page 22           | 4  | See Chapter "Assembling instruction EasyClamp DN25", page 22           |
| 5 | See Chapter "Assembling instruction shut off tap", page 24             | 6  | See Chapter "Assembling instruction EasyClamp DN25", page 22           |
| 7 | See Chapter "Assembling instruction EasyClamp DN25", page 22           | 8  | See Chapter "Assembling instruction shut off tap", page 24             |
| 9 | See Chapter "Assembling instruction EasyClamp DN25", page 22           | 10 | See Chapter "Assembling instruction EasyClamp DN25", page 22           |

### 5.4.7 Installing the single receiver (option)

#### Installation order

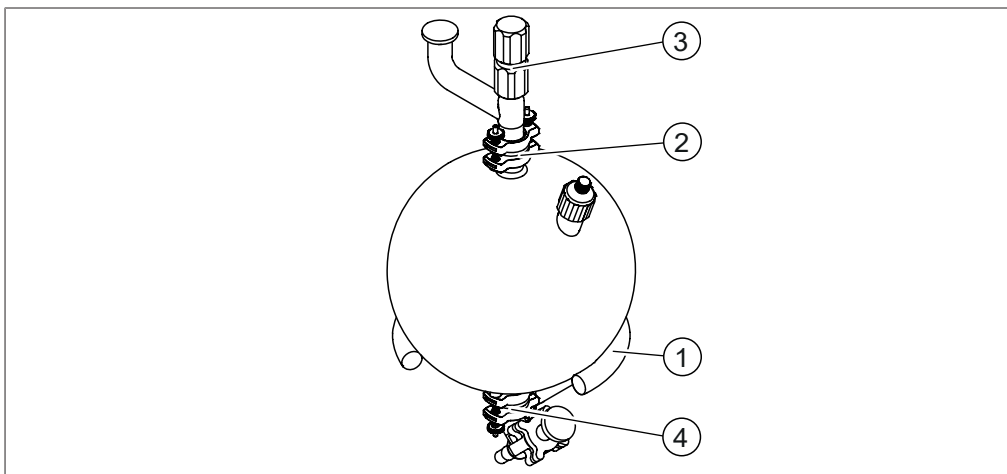

Fig. 9: Installation order single receiver

- |   |  |   |  |
|---|--|---|--|
| 1 | See Chapter "Assembling instruction receiving vessel support", page 24 | 2 | See Chapter "Assembling instruction EasyClamp DN25", page 22 |
| 3 | See Chapter "Assembling instruction shut off tap", page 24             | 4 | See Chapter "Assembling instruction EasyClamp DN25", page 22 |

### 5.4.8 Connecting the receiver with the glass assembly (example)

Precondition:

- The requested receiver is installed.
- The requested glass assembly is installed.
- ▶ Adjust the height of the receiver with the wheel.

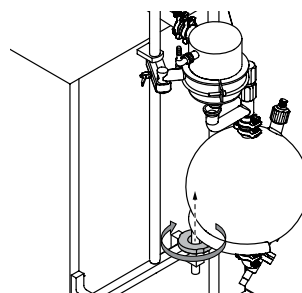

- ▶ Attach the two glass pieces.

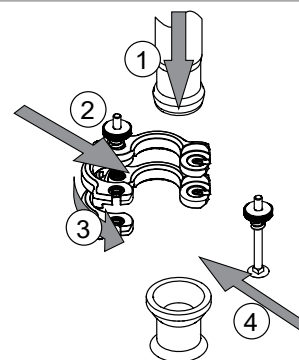

- ▶ Secure the connection in place with the easy clamp.

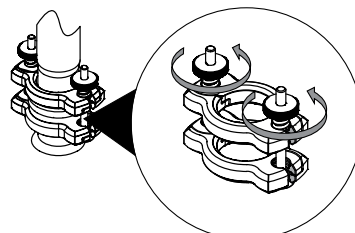

## 5.5 Installing the vacuum supply

### 5.5.1 Installing the vacuum pump holder (option)

- ▶ Hold the vacuum pump holder at the indicated position and fix it with the side screws.

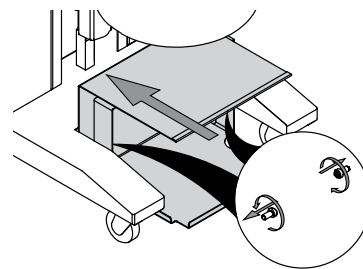

- ▶ Attach the rear screws.

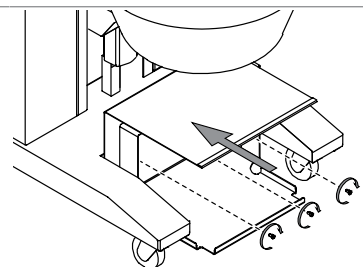

### 5.5.2 Installing a BUCHI vacuum pump (option)

Precondition:

- The BUCHI vacuum pump is prepared. See related documentation
- ▶ If possible, locate the vacuum pump at the vacuum pump location of the instrument. See Chapter 3.2 "Configuration", page 13
- ▶ Attach the vacuum hose to the Aeration valve.

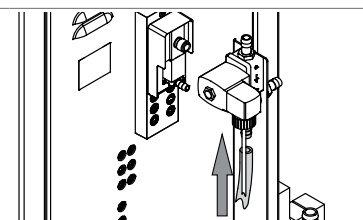

- ▶ Connect the vacuum pump cable to the related connection on the instrument. See Chapter 3.2 "Configuration", page 13

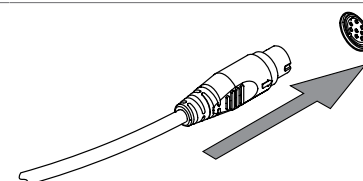

- ▶ Connect the vacuum pump power supply cable to the related connection on the instrument. See Chapter 3.2 "Configuration", page 13

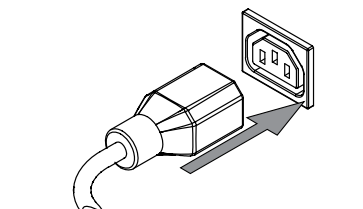

- ▶ Connect the aeration valve cable to the related connection on the instrument. See Chapter 3.2 "Configuration", page 13

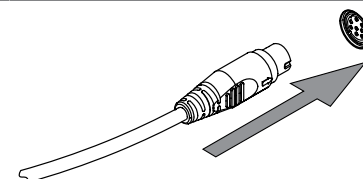

### 5.5.3 Installing a non BUCHI vacuum pump (option)

Precondition:

- ☑ The vacuum meets the technical specifications.  
See Chapter 3.5 "Technical data", page 17

- ▶ If a vacuum pump is used, prepare the vacuum pump. See related documentation.

- ▶ Attach the vacuum valve to the instrument.

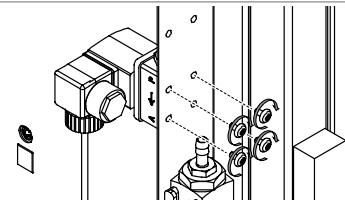

- ▶ Attach the vacuum hose to the vacuum valve.

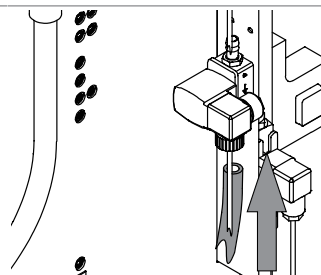

- ▶ Connect the vacuum valve and the aeration valve with a vacuum hose.

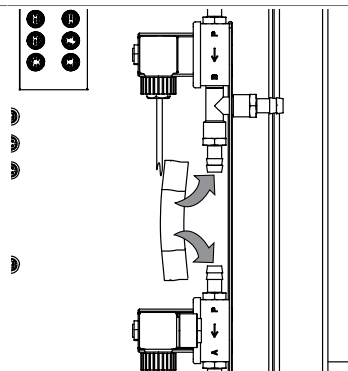

- ▶ Connect the vacuum valve cable to the instrument. See Chapter 3.2 "Configuration", page 13

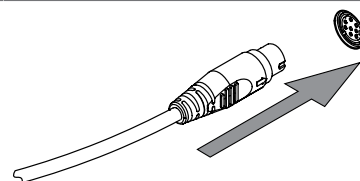

### 5.5.4 Installing the vacuum connection glass assembly R (option)

- ▶ Attach the vacuum hoses to the Aeration valve.

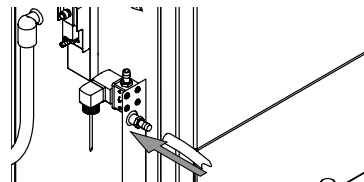

- ▶ Attach the vacuum hose to Y piece

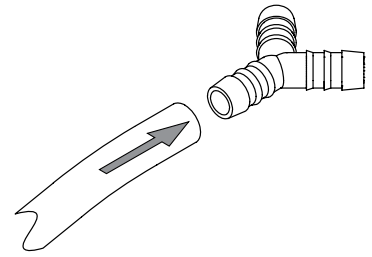

- ▶ Attach the condenser vacuum hoses to the Y piece.

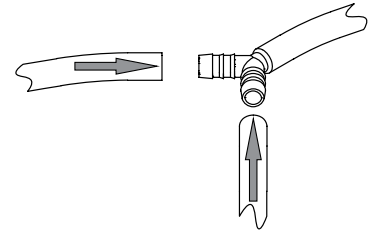

- ▶ Attach the vacuum hoses to the condensers.

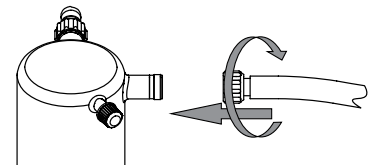

- ▶ Attach the hose barb to the condenser.

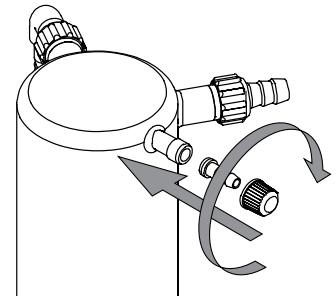

- ▶ Attach the vacuum hose for the VacuBox onto the condenser

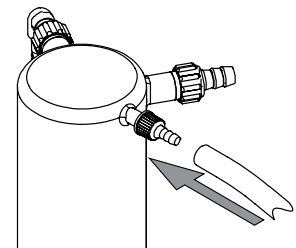

- ▶ Attach the hose barb to the VacuBox.

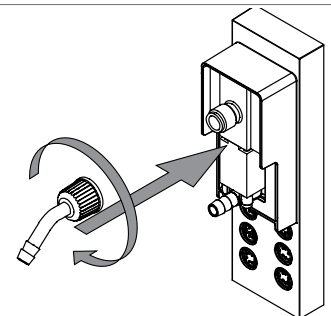

- ▶ Attach the vacuum hose to the VacuBox.

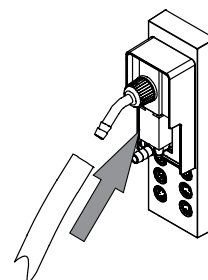

### 5.5.5 Installing the vacuum connection glass assembly D (option)

- ▶ Attach the vacuum hoses to the Aeration valve.

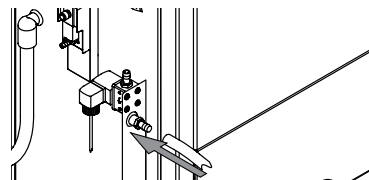

- ▶ Attach the vacuum hose to the condenser.

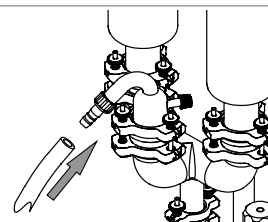

- ▶ Attach the hose barb to the condenser.

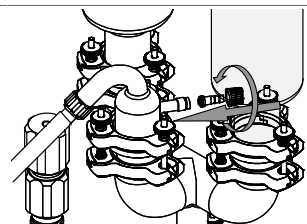

- ▶ Attach the vacuum hose to the condenser.

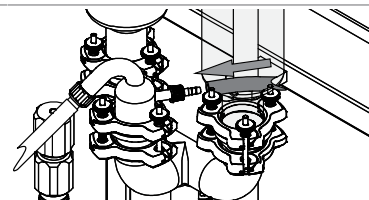

- ▶ Attach the hose barb to the VacuBox.

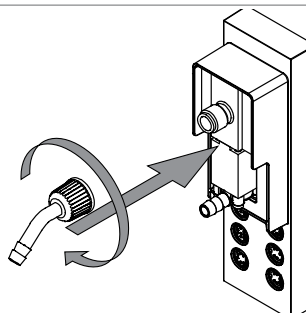

- ▶ Attach the vacuum hose to the VacuBox.

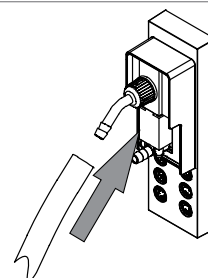



## 5.6 Installing the cooling water supply

### 5.6.1 Installing the cooling water supply with a recirculating chiller (option)

Precondition:

- ☑ The recirculating chiller is prepared. See related documentation.
- ☑ The inlet water hose for the condenser is prepared.

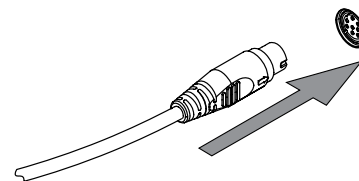

- ▶ Connect the chiller cable to the related connection on the instrument. See Chapter 3.2 "Configuration", page 13

- ▶ Attach the inlet water supply hose to the Y-piece.

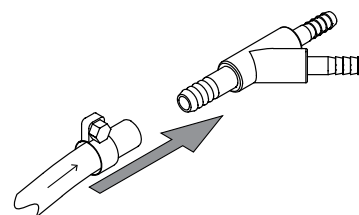

- ▶ Attach the inlet condenser hoses to the Y-piece.
- ▶ Secure the hoses in place with a hose clamp.

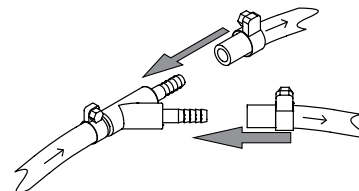

- ▶ Attach the water hose to the inlet connection.

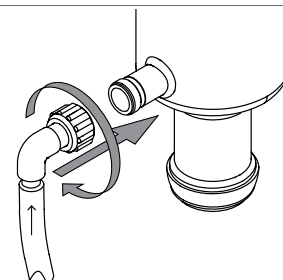

- ▶ Attach the hose to the outlet connection.

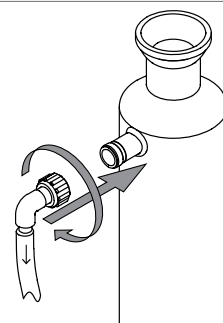

- ▶ Attach the outlet water supply hose to the Y-piece.

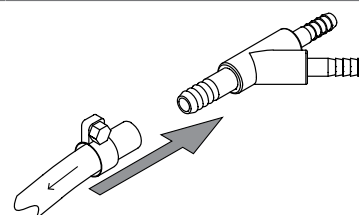

- ▶ Attach the outlet condenser hoses to the Y-piece.
- ▶ Secure the hoses in place with a hose clamp.

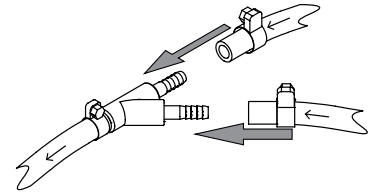

- ▶ Attach the outlet water supply hose to the chiller.

### 5.6.2 Installing the cooling water supply without a recirculating chiller (option)

Precondition:

- The water supply meets the technical specification. See Chapter 3.5 "Technical data", page 17

- ▶ Attach the water supply hose to the cooling water tap.
- ▶ Secure the water supply hose in place with a hose clamp.

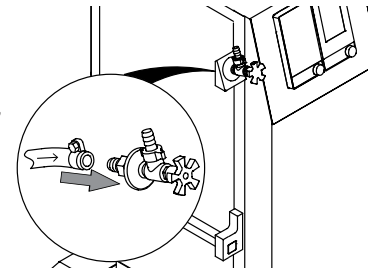

- ▶ Attach the condenser hose to the cooling water tap.

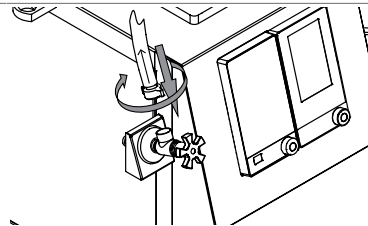

- ▶ Attach the inlet water supply hose to the Y-piece.

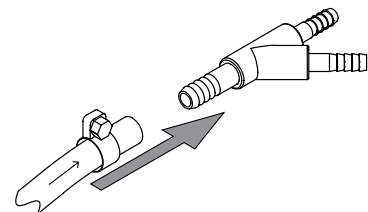

- ▶ Attach the inlet condenser hoses to the Y-piece.
- ▶ Secure the hoses in place with a hose clamp.

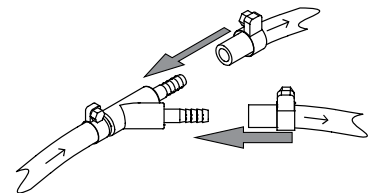

- ▶ Attach the water hose to the inlet connection.

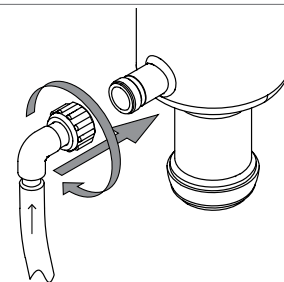

- ▶ Attach the hose to the outlet connection.

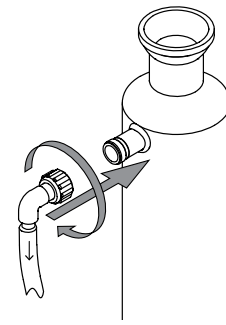

- ▶ Attach the outlet water supply hose to the Y-piece.

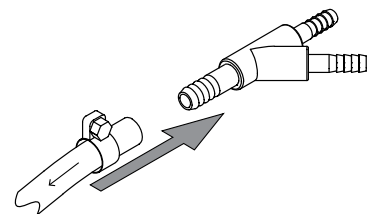

- ▶ Attach the outlet condenser hoses to the Y-piece.
- ▶ Secure the hoses in place with a hose clamp.

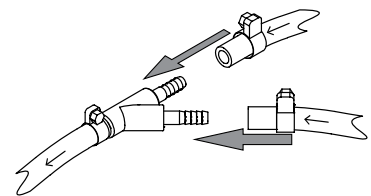

- ▶ Put the other end of the hose in a sink.

## 5.7 Heating bath installations

### 5.7.1 Installing the splash protection (option)

- ▶ Attach the rear fender onto the heating bath.

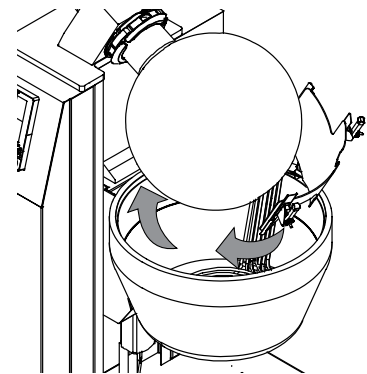

- ▶ Secure the rear fender in place.

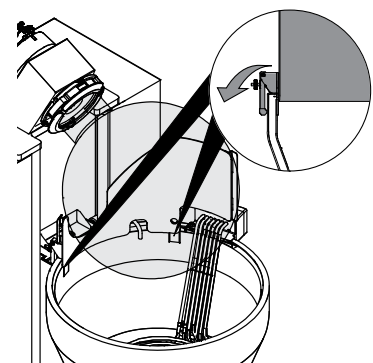

### 5.7.2 Installing the heating bath replenishment (option)



**NOTE**

If oil is used as heating medium do not install the heating bath replenishment.

- ▶ Attach the water supply to the heating bath replenishment.
- ▶ Secure the hose in place with a hose clamp.

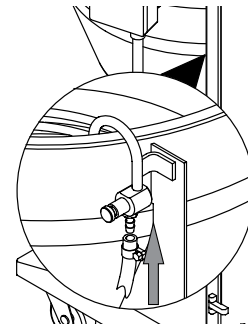

### 5.7.3 Installing the drain connection at the heating bath



**NOTE**

- ▶ If a heating medium other than clean water is used:
  - ⇒ Obey local regulations and statutory requirements regarding disposal.
- ▶ Attach the drain hose to the drain valve.

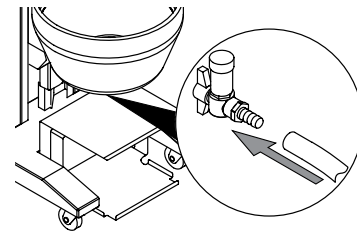

- ▶ Install the other end on a receiving system (e.g. drain).

### 5.7.4 Setting the heating bath reaction during a power interruption

Status	Explanation
On	The heating bath stays in position.
Off	The heating bath moves down.

- ▶ Push and hold the down button.
- ▶ Set the On /off master switch to On.

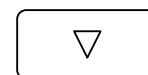

+

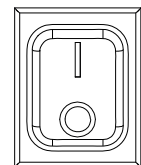

- ▶ Tap the down button to change the status

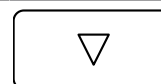

- ▶ Tap the **AERATE** button.
  - ⇒ The setting is saved.
  - ⇒ The menu close.



## 5.8 Installing the sensors



### NOTE

Glassware is delivered as per the purchase order, order confirmation and delivery note.

### 5.8.1 Installing the vapor temperature sensor

According to the configuration there are two locations where the sensor can be installed:

- Chapter "Installing the vapor temperature sensor at the glass assembly R (option)", page 37
- Chapter "Installing the vapor temperature sensor at the glass assembly D (option)", page 37

#### Installing the vapor temperature sensor at the glass assembly R (option)

- ▶ Attach the vapor temperature sensor to the distribution piece.

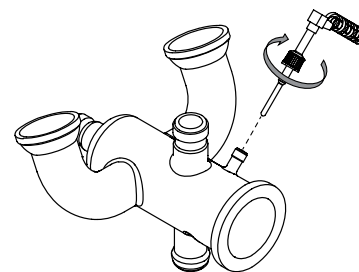

- ▶ Connect the vapor temperature sensor cable to the related connection on the instrument. See Chapter 3.2 "Configuration", page 13

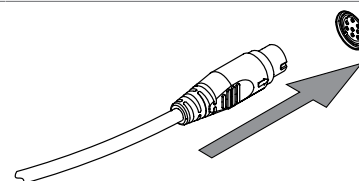

#### Installing the vapor temperature sensor at the glass assembly D (option)

- ▶ Attach the vapor temperature sensor to the U-tube.

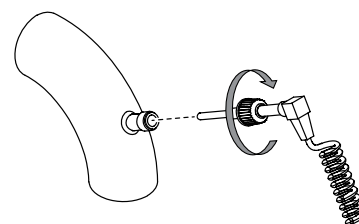

- ▶ Connect the vapor temperature sensor cable to the related connection on the instrument. See Chapter 3.2 "Configuration", page 13

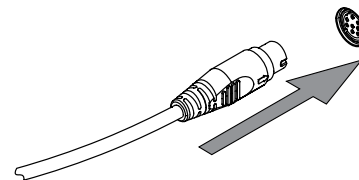

### 5.8.2 Installing the cooling temperature sensor (option)



### NOTE

Two condenser configuration (option)

- ▶ Install the sensor in one condenser circle.

- ▶ Install the cooling water temperature sensor in the cooling water outlet of the condenser.

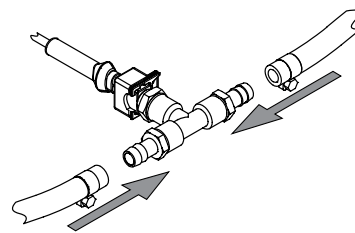

- ▶ Connect the sensor cable to the related connection on the instrument. See Chapter 3.2 "Configuration", page 13

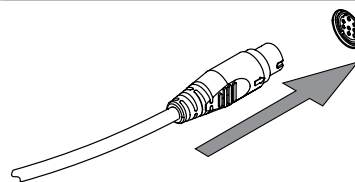

### 5.8.3 Installing the foam sensor (option)

Precondition:

- The distribution piece has the option to install a foam sensor.
- ▶ Attach the foam sensor to the to the distribution piece.

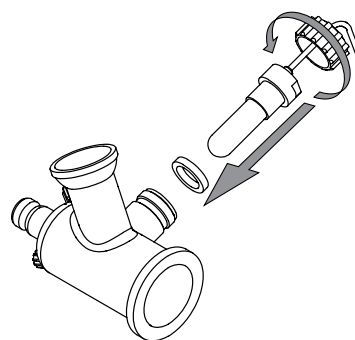

- ▶ Connect the sensor cable to the related connection on the instrument. See Chapter 3.2 "Configuration", page 13

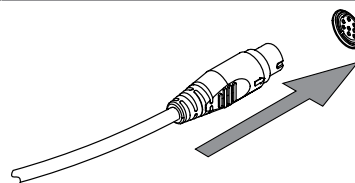

- ▶ If necessary, adjust the sensor. See Chapter 10.7 "Adjusting the foam sensor", page 57

### 5.8.4 Installing the cooling water flow sensor (option)

- ▶ Attach the cooling water sensor to the instruments with screws.

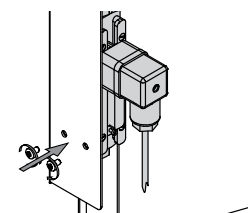

- ▶ Install the cooling water sensor within the cooling water supply.
- ▶ Secure the hoses in place with hose clamps.

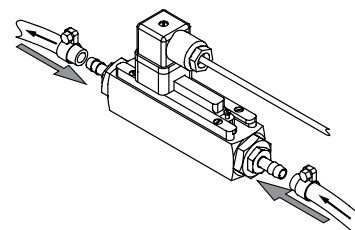

- ▶ Connect the sensor cable to the related connection on the instrument. See Chapter 3.2 "Configuration", page 13

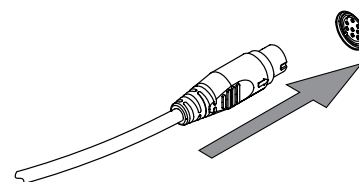

- ▶ Activate the sensor in the sensor menu. See Chapter 5.8.6 "Setting up the sensors", page 39
- ▶ Calibrate the cooling water flow sensor. See Chapter 10.5 "Adjusting the cooling water flow sensor", page 57

### 5.8.5 Installing the level sensor (option)

- ▶ Attach the level sensor to the receiving vessel with the band.

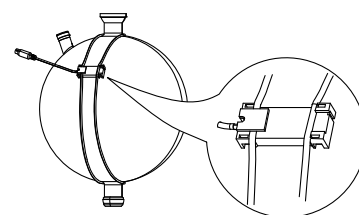

- ▶ Connect the sensor cable to the related connection on the instrument. See Chapter 3.2 "Configuration", page 13

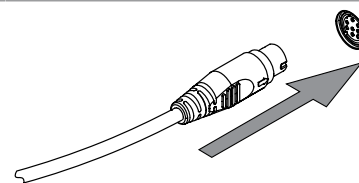

- ▶ Activate the sensor in the sensor menu. See Chapter 5.8.6 "Setting up the sensors", page 39
- ▶ If necessary, adjust the sensor. See Chapter 10.6 "Adjusting the level sensor", page 57

### 5.8.6 Setting up the sensors

Activate the following sensors in the menu:

- Level sensor 1 see Chapter 5.8.5 "Installing the level sensor (option)", page 39
- Level sensor 2 see Chapter 5.8.5 "Installing the level sensor (option)", page 39
- Cooling water flow sensor see Chapter 5.8.4 "Installing the cooling water flow sensor (option)", page 38

Status	Explanation
On	The related sensor is active.
Off	The related sensor is deactivated.

Precondition:

- ☑ Make sure that the sensors you wish to active are connected to the instrument.



+

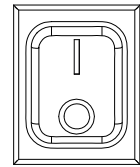

- ▶ Push and hold the up button.
- ▶ Set the On /off master switch to On.
- ⇒ The instrument shows the status for the cooling water flow sensor.

- ▶ Tap the up button to change the status for the cooling water sensor according the requirements.



- ▶ Tap the Aerate button on the interface.

⇒ The setting for the cooling water sensor is saved.

⇒ The instrument shows the status for the level sensor 1.



- ▶ Tap the up button to change the status for the level sensor 1 according the requirements.

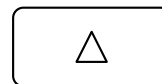

- ▶ Tap the Aerate button on the interface.

⇒ The setting for the level sensor 1 is saved.

⇒ The instrument shows the status for the level sensor 2.



- ▶ Tap the up button to change the status for the level sensor 2 according the requirements.

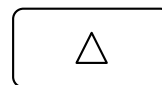

- ▶ Tap the Aerate button on the interface.

⇒ The setting for the level sensor 2 is saved.

⇒ The setting menu close.



## 5.9 Preparing the instrument for remote control (option)

Precondition:

- ☑ The cover is available. See Chapter 12.2 "Spare parts and accessories", page 61
- ☑ An extension cable is available. See Chapter 12.2 "Spare parts and accessories", page 61

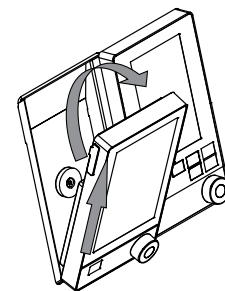

- ▶ Remove the interface from the instrument.
- ▶ Disconnect all communication cables.



- ▶ Install the cover in place.

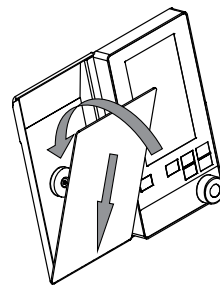

- ▶ Connect the connection cable to the BUCHI standard communication port (COM) on the interface.

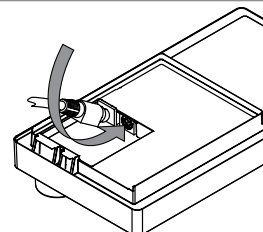

- ▶ Connect the other end of the connection cable to the BUCHI standard communication port (COM) on the instrument. See Chapter 3.2 "Configuration", page 13

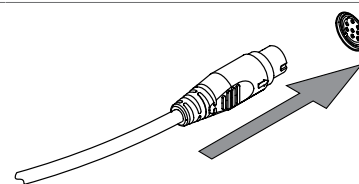

## 6 Layout of the interface

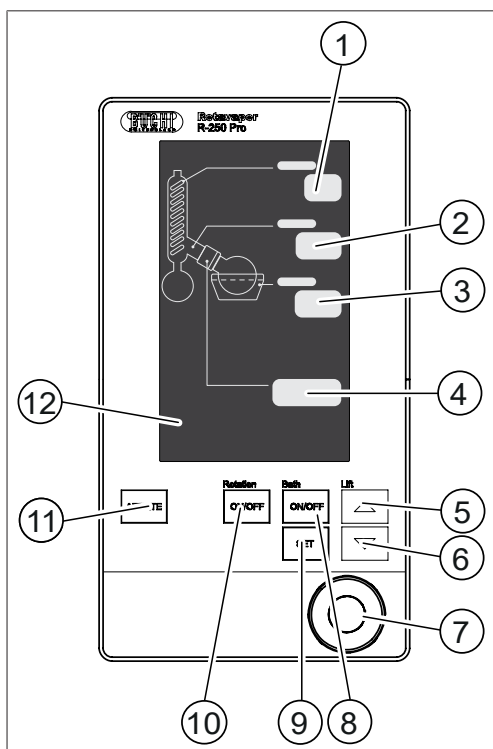

Fig. 10: Interface

- |   |                        |
|---|------------------------|
| <p>1 Cooling temperature</p> <p>2 Vapor temperature</p> <p>3 Bath temperature</p> <p>4 According to the current operation:</p> <ul style="list-style-type: none"> <li>• Rotation speed</li> <li>• Error code</li> </ul> <p>5 UP button</p> <p>According to the current operation:</p> <ul style="list-style-type: none"> <li>• Bath lift</li> <li>• Sensor settings</li> </ul> <p>6 Down button</p> <p>According to the current operation:</p> <ul style="list-style-type: none"> <li>• Bath lift</li> <li>• Heating bath settings</li> </ul> <p>7 Navigation control</p> <p>8 <b>ON/OFF</b> button heating bath</p> <p>9 <b>SET</b> button bath temperature</p> <p>10 <b>ON/OFF</b> button rotation</p> <p>11 <b>AERATE</b> button</p> <p>According to the current operation:</p> <ul style="list-style-type: none"> <li>• Aerating the system</li> <li>• Confirm</li> </ul> | <p>12 Status panel</p> |
|---|------------------------|

## 7 Preparing for an evaporation

### 7.1 Installing and removing the evaporation flask

**NOTE**

Removing is done in reverse sequence.

- ▶ Move the heating bath in a lower position.

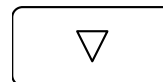

- ▶ Put the evaporation flask and the flask handler (option) on the instrument.

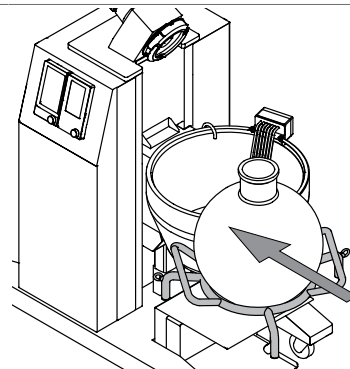

- ▶ Lift the heating bath and move the evaporation flask to the snap flange.

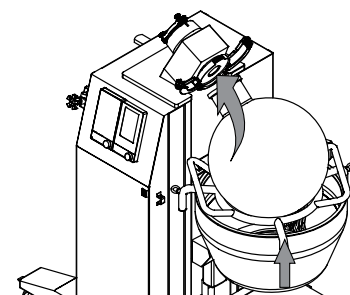

- ▶ Close the snap flange coupling.

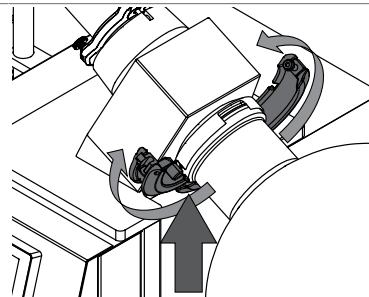

- ▶ Torque the screw to 4 NM.

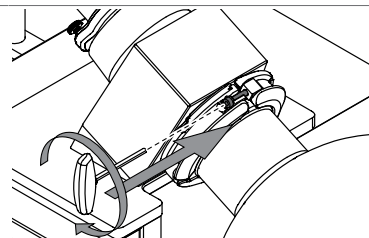

- ▶ Lower the heating bath.

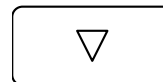

- ▶ Remove the flask handler.

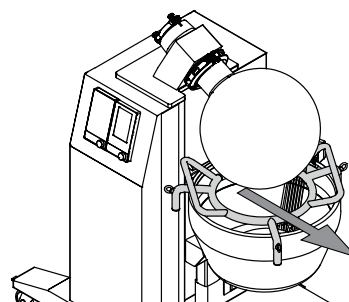

## 7.2 Operating the inlet valve

- ▶ Attach the solvent hose to the inlet valve.

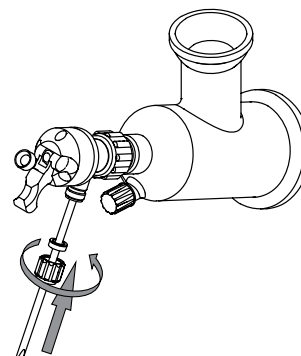

- ▶ Put the solvent hose into the solvent.

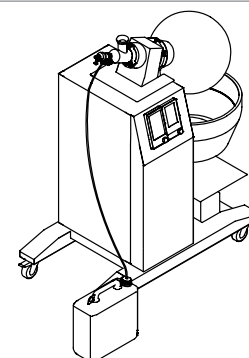

- ▶ Set the flow rate.

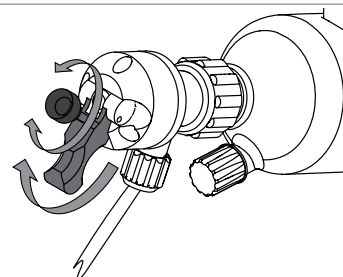

## 7.3 Preparing the heating bath



### ⚠ CAUTION

Risk of skin burns from oil splashes

- ▶ Do not put water into hot oil.
- ▶ Make sure that the heating oil complies with the technical data. See Chapter 3.5 "Technical data", page 17

- ▶ Make sure, that the drain valve is closed.

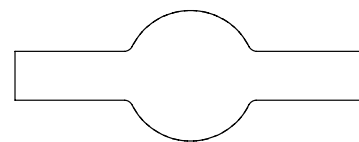

- ▶ Fill heating medium until the max. filling level.  
Max. filling level see Chapter 3.2  
"Configuration", page 13

## 7.4 Draining distillate

Precondition:

- A distillate collection is available.
- ▶ Close the shut off tap.
- ▶ Make sure, that the plunger closes the hole.

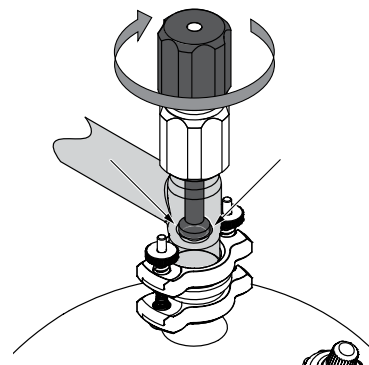

- ▶ Loose the aeration valve.

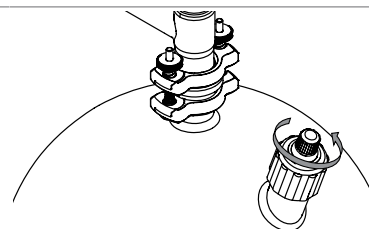

- ▶ Open the drain valve.

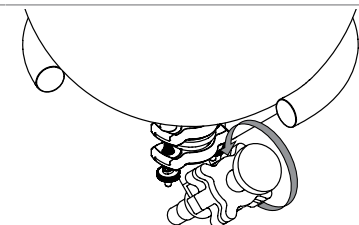

## 7.5 Operating the splash protection



### NOTE

Removing is done in reverse sequence.

Precondition:

- The installation is carried out. See Chapter 5.7.1 "Installing the splash protection (option)", page 35
- ▶ Attach the splash protection onto the instrument.

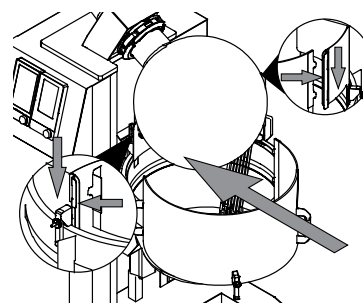

- ▶ Secure the splash protection in place.

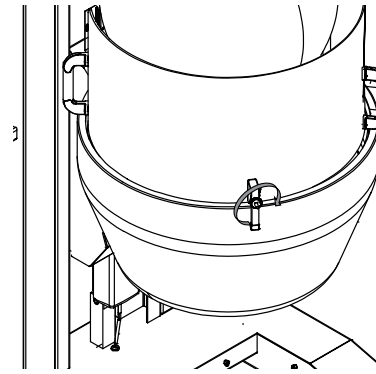

## 8 Carrying out an evaporation



### NOTE

Using the control system. See operation manual "*Interface I-300 Pro*".

### 8.1 Preparing the instrument

Precondition:

- All commissioning operations have been completed. See Chapter 5 "Installation", page 21
- Make sure that no defective sealings or glass parts are used.
- ▶ Set the On/Off master switch to On.
  - ⇒ The instrument is starting up.
- ▶ Check the filling level of the heating bath.

### 8.2 Starting an evaporation

- ▶ Attach the prepared evaporation flask to the instrument. See Chapter 7.1 "Installing and removing the evaporation flask", page 43
- ▶ Set heating bath temperature.
- ▶ Switch on the recirculating chiller or open the water tap.
- ▶ Set the vacuum option on the Interface. See operation manual "*Interface I-300 Pro*"
- ▶ Add product. Add product. See Chapter 7.2 "Operating the inlet valve", page 44
- ▶ Lift the heating bath.
- ▶ Start the rotation.

### 8.3 Task during an evaporation

- ▶ If necessary, carry out the following tasks:
  - Adjust the vacuum.
  - Adjust the bath temperature.
  - Adjust rotation speed.
  - If foam increase, press the **Aerate** button.
  - Add product. See Chapter 7.2 "Operating the inlet valve", page 44
  - Remove distillate. See Chapter 7.4 "Draining distillate", page 45

### 8.4 Ending an evaporation

Precondition:

- The sample is evaporated.
- ▶ Press stop on the function bar at I-300Pro.
- ▶ Lower heating bath.
- ▶ Empty the receiver flask. See Chapter 7.4 "Draining distillate", page 45
- ▶ Wait until the evaporation flask temperature is less than 40 °C.
- ▶ Remove the evaporation flask. See Chapter 7.1 "Installing and removing the evaporation flask", page 43
- ▶ Clean the glassware.

## **8.5 Shutting down the instrument**

- ▶ Switch the On/Off master switch to off.



## 9 Cleaning and servicing



### NOTE

Users may only carry out the servicing and cleaning operations described in this section.

Any servicing and repair work which involves opening up the casing may only be carried out by BUCHI service technicians.

- ▶ Use only genuine BUCHI consumables and spare parts in order to ensure correct operation of the device and preserve the warranty.

### 9.1 Regular maintenance work

Component	Action	Frequency
Vacuum seal	<ul style="list-style-type: none"> <li>▶ Rinse the sealing with water or ethanol</li> <li>▶ Wipe the sealing lip with a soft lint-free cloth.</li> </ul>	monthly
Instrument	<ul style="list-style-type: none"> <li>▶ Perform a leak test. See operation manual "<i>Interface I-300 Pro</i>".</li> <li>▶ If necessary, search for leaks.</li> <li>▶ If necessary, change the vacuum seal. See Chapter 9.3 "Replacing the evaporation flask seal", page 50</li> </ul>	monthly
Glassware	<ul style="list-style-type: none"> <li>▶ Wipe down with a damp cloth.</li> </ul>	monthly
Heating bath	<ul style="list-style-type: none"> <li>▶ Check the heating bath.</li> <li>▶ If necessary, decalcify the heating bath.</li> </ul>	monthly
Casing	<ul style="list-style-type: none"> <li>▶ Wipe down the casing with a damp cloth.</li> <li>▶ If heavily soiled, use ethanol or a mild detergent.</li> </ul>	monthly
Warning symbols	<ul style="list-style-type: none"> <li>▶ Check that the warning symbols on the instrument are legible.</li> <li>▶ If they are dirty, clean them.</li> </ul>	monthly

### 9.2 Replacing the vacuum seal



### NOTE

Installing is done in reverse sequence.

- ▶ Remove the easy clamp from the instrument.

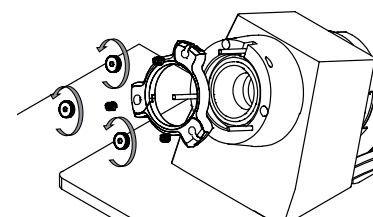

- ▶ Remove the sealing holder from the instrument.

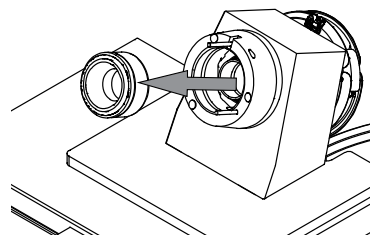

- ▶ Remove the sealing from the sealing holder.

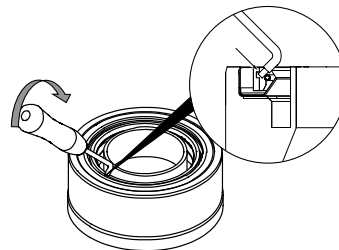

### 9.3 Replacing the evaporation flask seal



#### NOTE

Installing is done in reverse sequence.

- ▶ Remove the snap flange coupling with the provided tool.

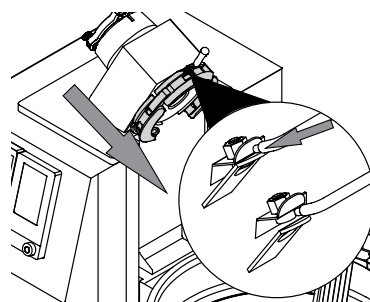

**NOTICE! Make sure, that the vapor duct does not fall down during carrying out this action step.**

- ▶ Remove the evaporation flask seal.

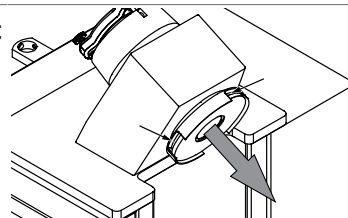

- ▶ If the vapor duct fall down, install the vapor duct. See Chapter 9.4 "Installing the vapor duct", page 50

### 9.4 Installing the vapor duct

- ▶ Put the vapor duct in the instrument.

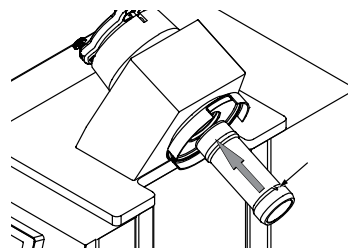

- ▶ Apply a light force and turn the vapor duct until the shaft starts turning.

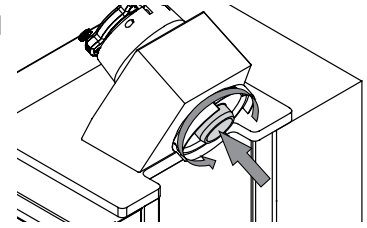

## 9.5 Setting max. heating bath temperature

- ▶ Push and hold the **SET** button.
- ▶ Set the On /off master switch to On.

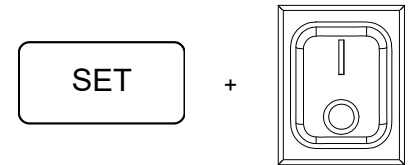

- ▶ Select the maximum heating bath temperature.

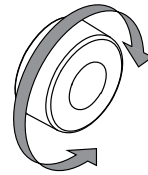

- ▶ Tap the **AERATE** button.
- ⇒ The setting is saved.
- ⇒ The setting menu close.



## 10 Help with faults

### 10.1 Troubleshooting

Problem	Possible cause	Action
The display is black	No power.	<ul style="list-style-type: none"> <li>▶ Establish an electrical connection.</li> <li>▶ Check the fuse.</li> </ul>
Display lights only in part	Display unit is defect.	▶ Contact BUCHI Customer Service.
Heating bath does not heat up	Temperature is set too low.	▶ Raise the temperature.
	Heater is switched off.	▶ Switch on the heater.
	The heater is defect.	▶ Contact BUCHI Customer Service.
	Temperature sensor is defect.	▶ Contact BUCHI Customer Service.
	Over temperature protection is active.	▶ Reset over-temperature protection. See Chapter 10.3 "Resetting the overtemperature protection", page 56
Evaporation flask does not rotate	The rotation speed is too low.	▶ Move the Navigation control clockwise.
	The drive belt is torn.	▶ Contact BUCHI Customer Service.
	The instrument is defect.	▶ Contact BUCHI Customer Service.
Buttons do not react	The buttons are defect.	▶ Contact BUCHI Customer Service.
Heating bath is not lifting	No power supply to the bath lift.	▶ Contact BUCHI Customer Service.
	Bath lift defect.	▶ Contact BUCHI Customer Service.

### 10.2 Error messages



#### NOTE

Press the **Aerate** button to confirm an error message.

<b>Error message</b>	<b>Possible cause</b>	<b>Solution</b>
E01	The bath temperature sensor is not connected. The bath temperature sensor is defective.	<ul style="list-style-type: none"> <li>▶ Switch off the instrument.</li> <li>▶ Wait until the heating bath temperature is less than 40 °C.</li> <li>▶ Start the instrument again.</li> <li>▶ Contact BUCHI Customer Service.</li> </ul>
E02	The lift motor is defective. The lift motor is blocked.	<ul style="list-style-type: none"> <li>▶ Switch off the instrument.</li> <li>▶ Check for causes of the blocking and remove.</li> <li>▶ Contact BUCHI Customer Service.</li> </ul>
E03	The rotary drive defective. The rotary drive is blocked.	<ul style="list-style-type: none"> <li>▶ Switch off the instrument.</li> <li>▶ Rotate evaporating flask manually.</li> <li>▶ Check for causes of the blocking and remove.</li> <li>▶ Contact BUCHI Customer Service.</li> </ul>
E04	The battery voltage is too low. The PB battery is weak. The PB battery is defective.	<ul style="list-style-type: none"> <li>▶ Switch on the instrument.</li> <li>▶ Wait eight hours.</li> <li>⇒ The batteries are recharged.</li> <li>▶ Contact BUCHI Customer Service.</li> </ul>
E05	Hardware malfunction.	<ul style="list-style-type: none"> <li>▶ Start the instrument again.</li> <li>▶ Contact BUCHI Customer Service.</li> </ul>
E06	Short circuit at the aeration valve.	<ul style="list-style-type: none"> <li>▶ Disconnect the aeration valve.</li> <li>▶ Start the instrument again.</li> <li>▶ Replace the aeration valve.</li> <li>▶ Contact BUCHI Customer Service.</li> </ul>
E07	Short circuit at the cooling water valve.	<ul style="list-style-type: none"> <li>▶ Disconnect the cooling water valve.</li> <li>▶ Start the instrument again.</li> <li>▶ Replace the cooling water valve.</li> <li>▶ Contact BUCHI Customer Service.</li> </ul>

Error message	Possible cause	Solution
E08	Short circuit at the vacuum valve.	<ul style="list-style-type: none"> <li>▶ Disconnect the cooling water valve.</li> <li>▶ Start the instrument again.</li> <li>▶ Replace the cooling water valve.</li> <li>▶ Contact BUCHI Customer Service.</li> </ul>
E12	The Cooling medium flow is insufficient.	<ul style="list-style-type: none"> <li>▶ Increase the cooling water flow.</li> <li>▶ Press the <b>Aerate</b> button.</li> <li>▶ Adjust the cooling water flow sensor. See Chapter 10.5 "Adjusting the cooling water flow sensor", page 57</li> <li>▶ Replace the cooling water flow sensor.</li> <li>▶ Contact BUCHI Customer Service.</li> </ul>
E13	The receiving vessel 1 filling level is reached.	<ul style="list-style-type: none"> <li>▶ Empty receiving vessel 1.</li> <li>▶ Press the <b>Aerate</b> button.</li> <li>▶ Adjust the level sensor. See Chapter 10.6 "Adjusting the level sensor", page 57</li> <li>▶ Contact BUCHI Customer Service.</li> </ul>
E14	The receiving vessel 2 filling level is reached.	<ul style="list-style-type: none"> <li>▶ Empty receiving vessel 2.</li> <li>▶ Press the <b>Aerate</b> button.</li> <li>▶ Adjust the level sensor. See Chapter 10.6 "Adjusting the level sensor", page 57</li> <li>▶ Contact BUCHI Customer Service.</li> </ul>
E26	Short circuit at the bath temperature sensor.	<ul style="list-style-type: none"> <li>▶ Start the instrument again.</li> <li>▶ Contact BUCHI Customer Service.</li> </ul>
E27	Short circuit at the vapor temperature sensor.	<ul style="list-style-type: none"> <li>▶ Disconnect the vapor temperature sensor.</li> <li>▶ Start the instrument again.</li> <li>▶ Replace the vapor temperature sensor.</li> <li>▶ Contact BUCHI Customer Service.</li> </ul>

Error message	Possible cause	Solution
E28	Short circuit at the cooling water temperature sensor.	<ul style="list-style-type: none"> <li>▶ Disconnect the cooling water temperature sensor.</li> <li>▶ Start the instrument again.</li> <li>▶ Replace the cooling water temperature sensor.</li> <li>▶ Contact BUCHI Customer Service.</li> </ul>
E31	The mechanical safety switch is activated.	<ul style="list-style-type: none"> <li>▶ Switch off the instrument.</li> <li>▶ Wait until the heating bath temperature is less than 40 °C.</li> <li>▶ Start the instrument again.</li> <li>▶ Refill heating transfer medium to minimum level.</li> <li>▶ Reset overtemperature protection. See Chapter 10.3 "Resetting the overtemperature protection", page 56</li> <li>▶ Contact BUCHI Customer Service.</li> </ul>
E32	Heating bath runs dry Temperature >200 °C	<ul style="list-style-type: none"> <li>▶ Switch off the instrument.</li> <li>▶ Wait until the heating bath temperature is less than 180 °C.</li> <li>▶ Refill heating transfer medium to minimum level</li> <li>▶ Contact BUCHI Customer Service.</li> </ul>
E33	The actual to set value difference is more than 15 °C.	<ul style="list-style-type: none"> <li>▶ Press the <b>Aerate</b> button.</li> <li>▶ Check set value for plausibility (e.g. set value less than ambient temperature)</li> <li>▶ If necessary, wait for the heating bath to cool down sufficiently</li> <li>▶ Contact BUCHI Customer Service.</li> </ul>
E40	Voltage drop or power outage	<ul style="list-style-type: none"> <li>▶ Press the <b>Aerate</b> button.</li> <li>▶ Make sure that the power supply meets the specifications. See Chapter 3.5 "Technical data", page 17</li> <li>▶ Contact BUCHI Customer Service.</li> </ul>

Error message	Possible cause	Solution
E41	Load limit exceeded by external electrical consumers (30 V).	<ul style="list-style-type: none"> <li>▶ Unplug the external consumer.</li> <li>▶ Replace external defective consumer.</li> <li>▶ Contact BUCHI Customer Service.</li> </ul>
E42	Load limit exceeded by external electrical consumers (24 V).	<ul style="list-style-type: none"> <li>▶ Unplug the external consumer.</li> <li>▶ Replace external defective consumer.</li> <li>▶ Contact BUCHI Customer Service.</li> </ul>
E43	Electronic malfunction	<ul style="list-style-type: none"> <li>▶ Start the instrument again.</li> <li>▶ Contact BUCHI Customer Service.</li> </ul>

### 10.3 Resetting the overtemperature protection

- ▶ Push the knob on the heating bath.

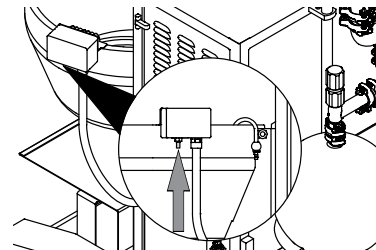

### 10.4 Replacing the inlet valve plunger



**NOTE**

Installing is done in reverse sequence.

- ▶ Loosen the screws that attach the inlet valve cover to the inlet valve.

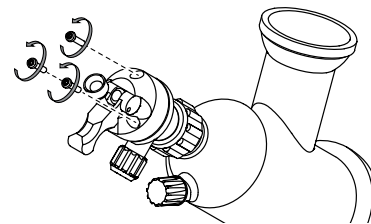

- ▶ Remove the inlet valve cover.

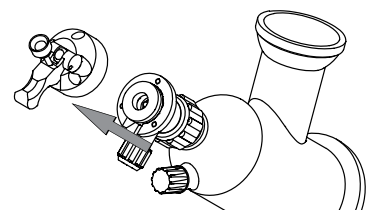

- ▶ Remove the plunger.

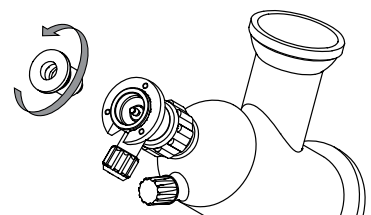



## 10.5 Adjusting the cooling water flow sensor

Precondition:

- The cooling water flow sensor is installed on the instrument. See Chapter 5.8.4 "Installing the cooling water flow sensor (option)", page 38
- The instrument is switched on.
- The display does not show an error.

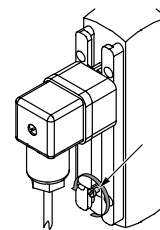

▶ Loosen the screw.

▶ Move the sensor until the display shows an error.

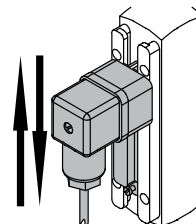

▶ Secure the sensor in place with the screw

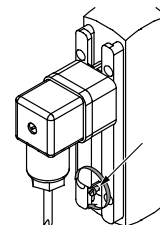

▶ Switch the water supply to on.

⇒ The error on the display disappear.

## 10.6 Adjusting the level sensor

Status LED	Explanation
ON	Liquid is detected
OFF	Liquid is not detected

Precondition:

- The sensor is connected to the instrument. See Chapter 5.8.5 "Installing the level sensor (option)", page 39
- ▶ Open the protective cap.
- ▶ Hold the Sensor next to the liquid.
- ▶ Adjust the adjustment screw so that the LED light is on when the sensor is near to the liquid.

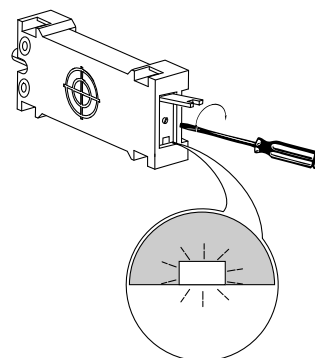

## 10.7 Adjusting the foam sensor

Status LED	Explanation
ON	Liquid is detected
OFF	Liquid is not detected

Precondition:

- ☑ The sensor is connected to the instrument. See Chapter 5.8.3 "Installing the foam sensor (option)", page 38

► Remove the protective cover.

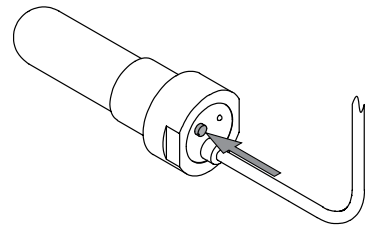

► Put the sensor 1 cm in the product.

► Adjust the adjustment screw so that the LED light is on when the sensor is near to the liquid.

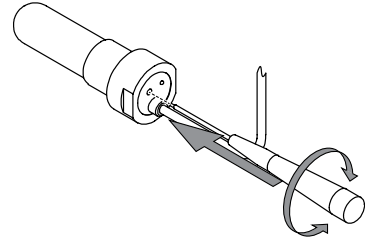

## **11 Taking out of service and disposal**

### **11.1 Taking out of service**

- ▶ Switch off the instrument and disconnect it from the mains power supply.
- ▶ Remove all tubing and communication cables from the device.

### **11.2 Disposal**

The operator is responsible for proper disposal of the instrument.

- ▶ When disposing of equipment observe the local regulations and statutory requirements regarding waste disposal.
- ▶ When disposing, observe the disposal regulations of the materials used. Materials used see Chapter 3.5 "Technical data", page 17

### **11.3 Returning the instrument**

Before returning the instrument, contact the BÜCHI Labortechnik AG Service Department.

<https://www.buchi.com/contact>

## 12 Appendix

### 12.1 Schematics

#### 12.1.1 Vacuum

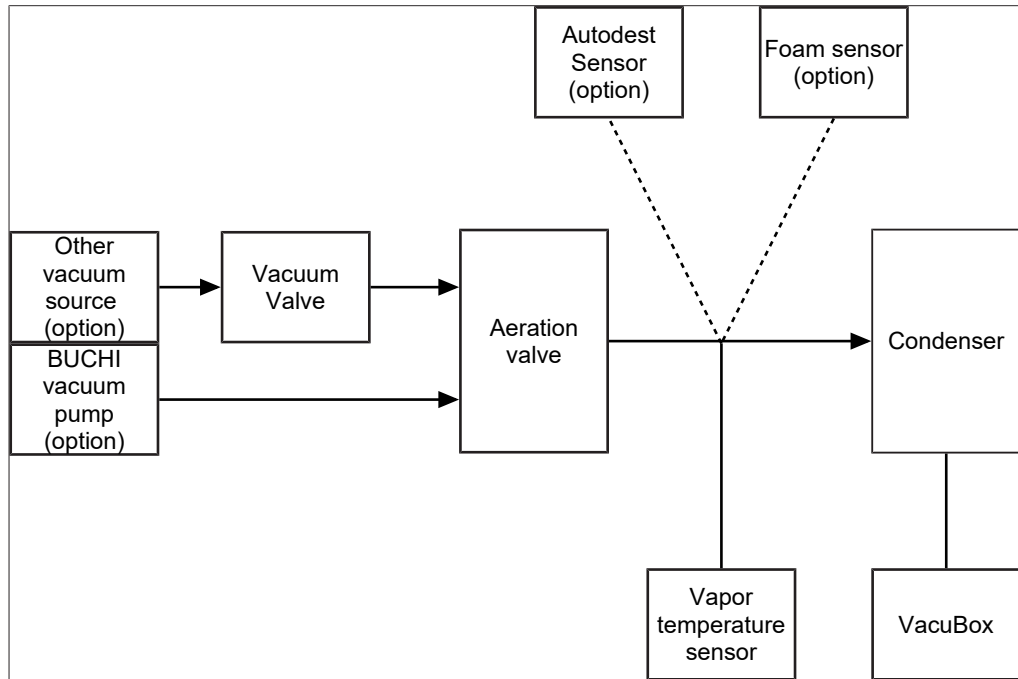

Fig. 11: Vacuum connection

#### 12.1.2 Cooling water circuit

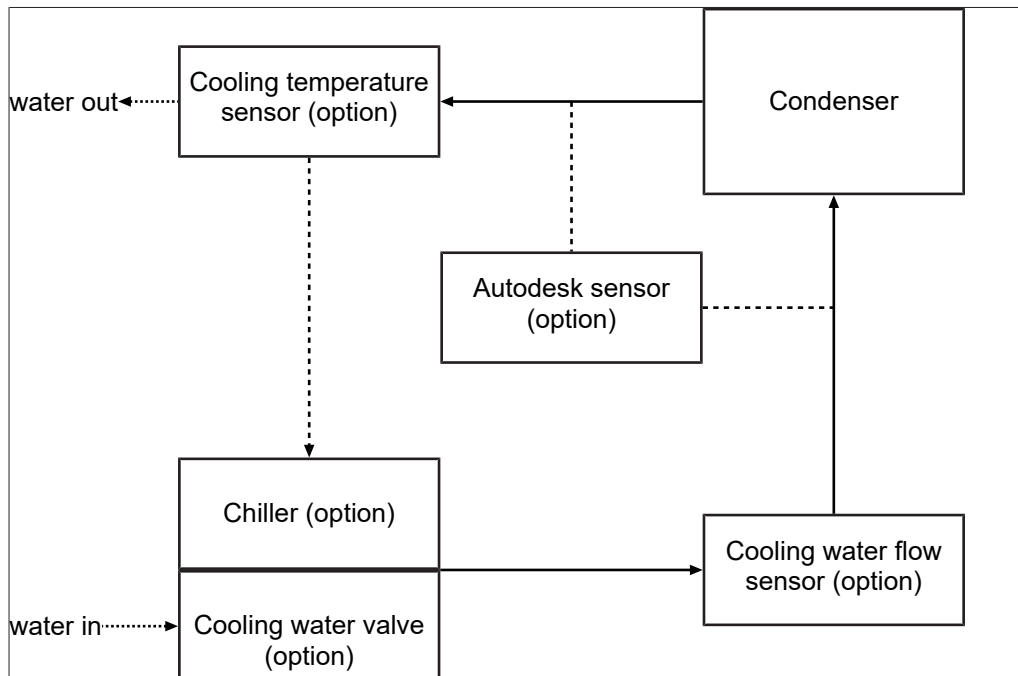
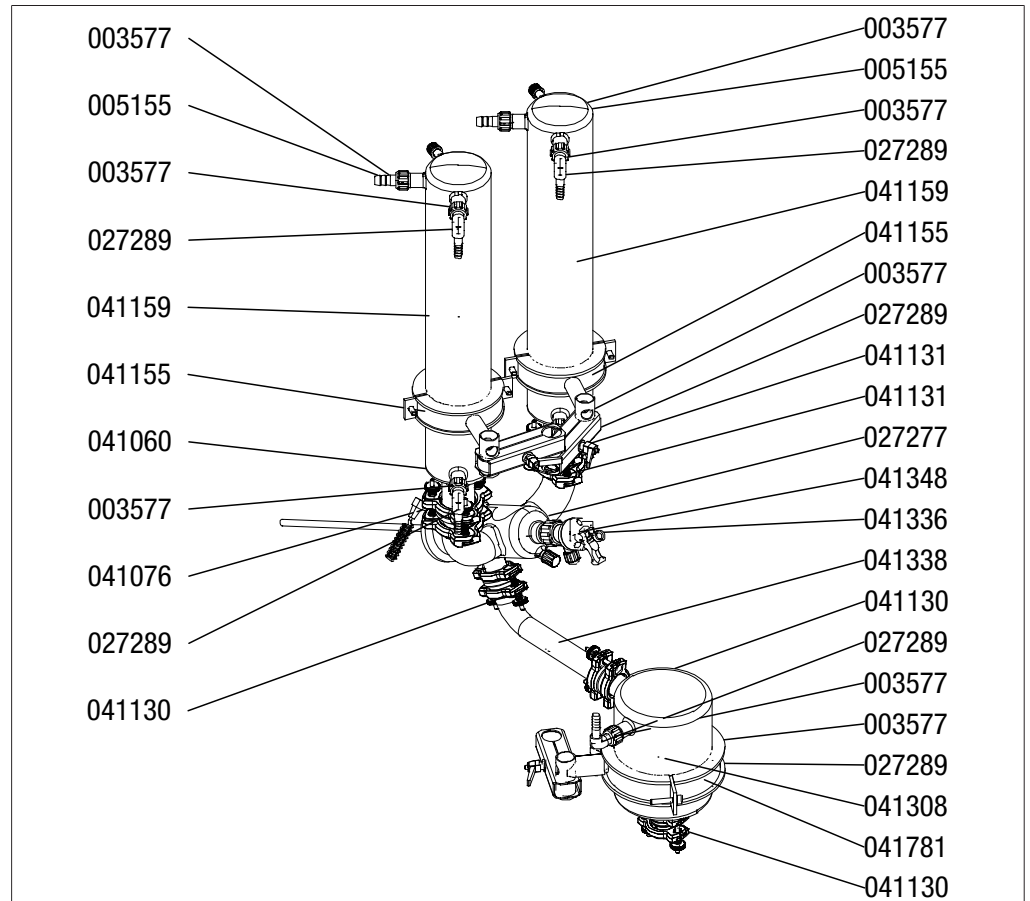

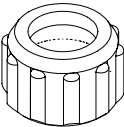

Fig. 12: Cooling water circuit





## 12.2 Spare parts and accessories

### 12.2.1 Spare parts glass ware

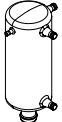
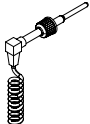
#### Spare parts glass assembly R

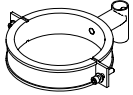
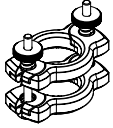
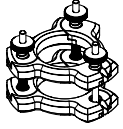
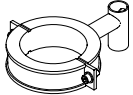

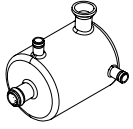
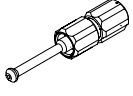

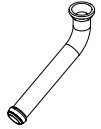
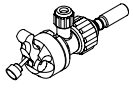
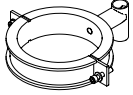
	Order no.	Image
Screw cap SVL 22	003577	
Screwed fitting Svl 22	027289	
Cooler Bullfrog, closed, PLG	027824	
Vapor temperature sensor, complete	041076	



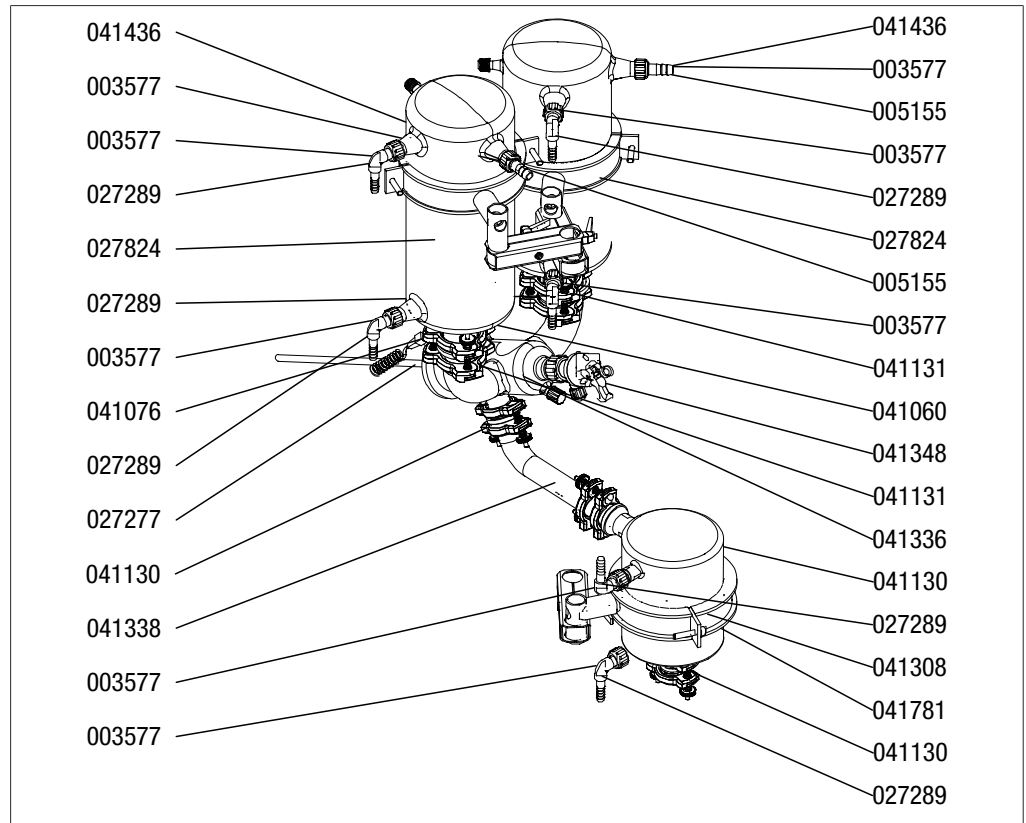

	<b>Order no.</b>	<b>Image</b>
Glass clamp 160 mm, complete	041120	
EasyClamp, DN25	041130	
EasyClamp, DN40	041131	
Pivoting clamp, complete	041151	
Glass clamp 100 mm, complete	041155	
Cooler, 3-coil, closed PLG	041159	
Set of bolts for EasyClamp, DN25	041240	
Set of bolts for EasyClamp, DN40	041241	
Distillate cooler PLG	041308	
Industrial tap, large	041060	
Distribution piece "R" PLG	041336	
Connection DN 25 PLG	041338	
Inlet valve, complete	041348	
Glass clamp 150 mm, complete	041781	

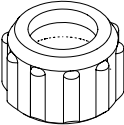
	<b>Order no.</b>
Seal PTFE	005155
PTFE hose connection SVL 22	027338
Tubing. PTFE, Ø8/10 mm, white, per m	027277
Use: Vacuum, feeding (industrial Rotavapor®).	

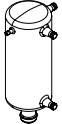
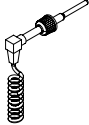
**Spare parts glass assembly RB**

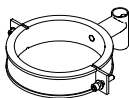
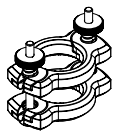
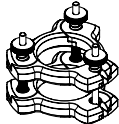
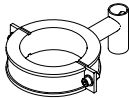

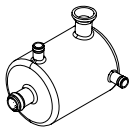
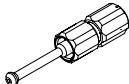
	<b>Order no.</b>	<b>Image</b>
Screw cap SVL 22	003577	
Screwed fitting SvL 22	027289	
Cooler Bullfrog, closed, PLG	027824	
Vapor temperature sensor, complete	041076	

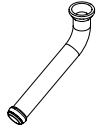
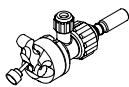
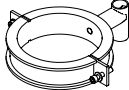

	<b>Order no.</b>	<b>Image</b>
Glass clamp 160 mm, complete	041120	
EasyClamp, DN25	041130	
EasyClamp, DN40	041131	
Pivoting clamp, complete	041151	
Glass clamp 100 mm, complete	041155	
Cooler, 3-coil, closed PLG	041159	
Set of bolts for EasyClamp, DN25	041240	
Set of bolts for EasyClamp, DN40	041241	
Distillate cooler PLG	041308	
Industrial tap, large	041060	
Distribution piece "R" PLG	041336	
Connection DN 25 PLG	041338	
Inlet valve, complete	041348	
Glass clamp 150 mm, complete	041781	





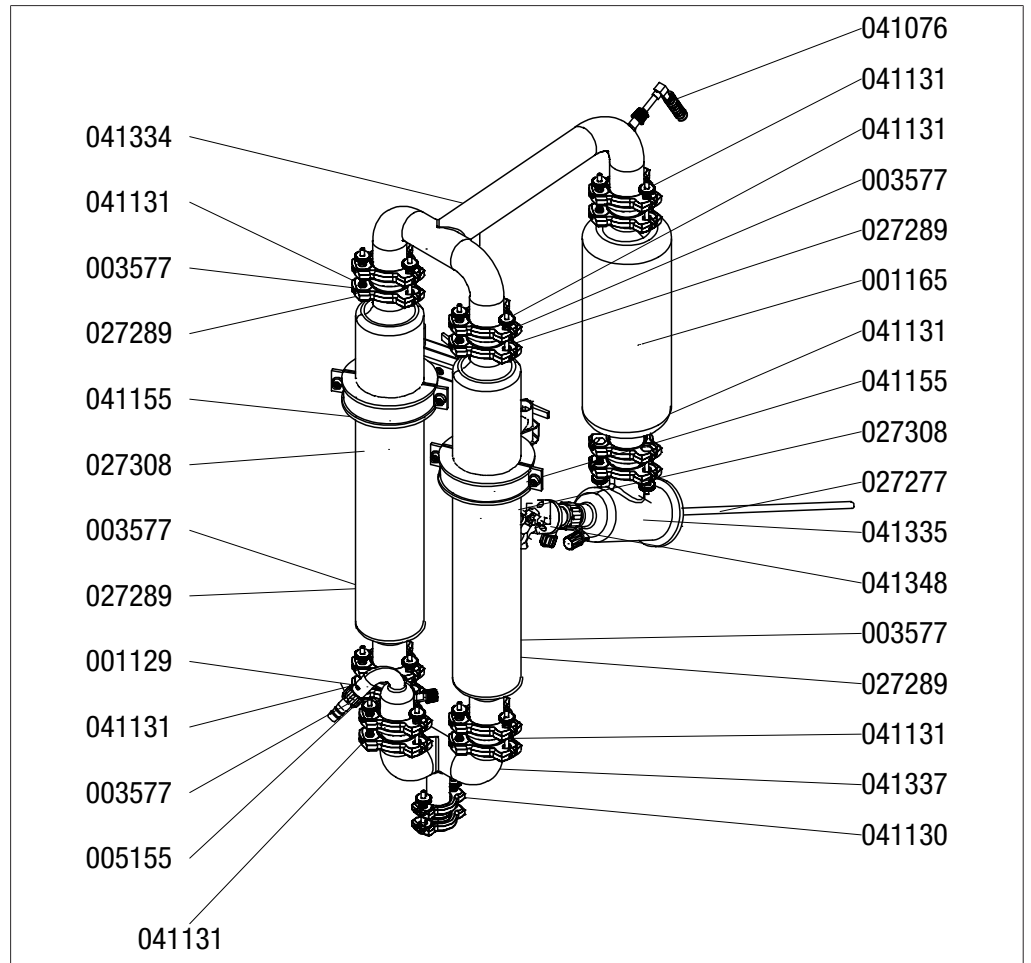



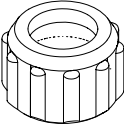

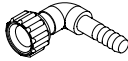
	Order no.
Seal PTFE	005155
PTFE hose connection SVL 22	027338
Tubing. PTFE, Ø8/10 mm, white, per m	027277
Use: Vacuum, feeding (industrial Rotavapor®).	

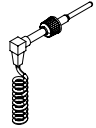
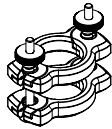
**Spare parts glass assembly D**

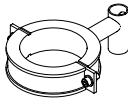

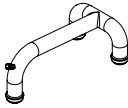

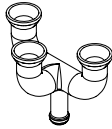
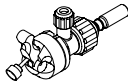
	Order no.	Image
Vacuum connector PLG	001129	
Expansion vessel PLG	001165	
Screw cap SVL 22	003577	

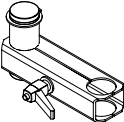



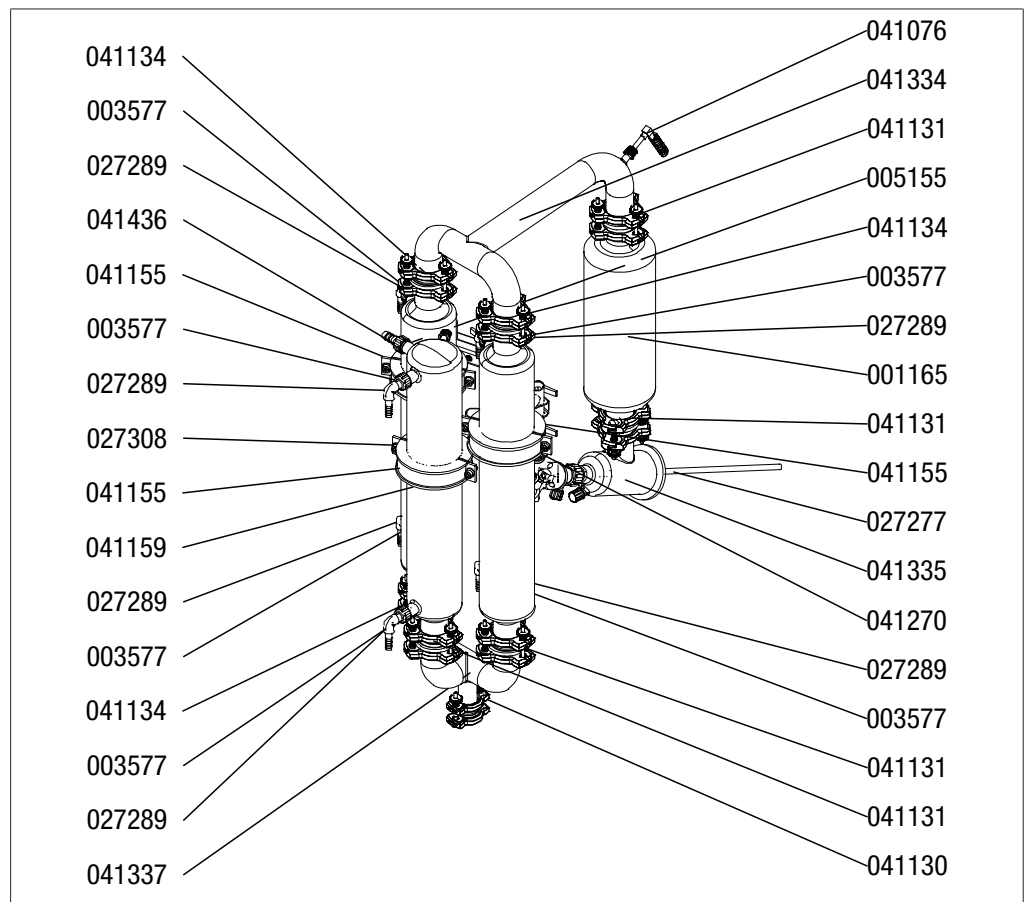

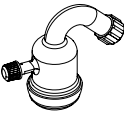

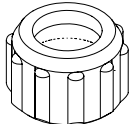

	<b>Order no.</b>	<b>Image</b>
Screwed fitting Svl 22	027289	
Cooler, 3 coil PLG	027308	
Vapor temperature sensor, complete	041076	
EasyClamp, DN25	041130	
EasyClamp, DN40	041131	
Pivoting clamp, complete	041151	
Glass clamp 100 mm, complete	041155	
Cooler, 3-coil, closed PLG	041159	
Set of bolts for EasyClamp, DN25	041240	
Set of bolts for EasyClamp, DN40	041241	
U-frame PLG	041334	
Distribution piece "D" PLG	041335	
Frame DN25/3xDN40 PLG	041337	
Inlet valve, complete	041348	

	Order no.	Image
Extension	041270	
<b>Order no.</b>		
PTFE hose connection SVL 22	027338	
Seal PTFE	005155	
Tubing. PTFE, Ø8/10 mm, white, per m	027277	
Use: Vacuum, feeding (industrial Rotavapor®).		

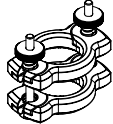
**Spare parts glass assembly D3**

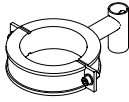

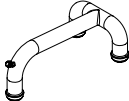
	Order no.	Image
Vacuum connector PLG	001129	
Expansion vessel PLG	001165	

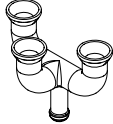
	<b>Order no.</b>	<b>Image</b>
Screw cap SVL 22	003577	
Screwed fitting Svl 22	027289	
Cooler, 3 coil PLG	027308	
Vapor temperature sensor, complete	041076	
EasyClamp, DN25	041130	
EasyClamp, DN40	041131	
Pivoting clamp, complete	041151	
Glass clamp 100 mm, complete	041155	
Cooler, 3-coil, closed PLG	041159	
Set of bolts for EasyClamp, DN25	041240	
Set of bolts for EasyClamp, DN40	041241	
U-frame PLG	041334	
Distribution piece "D" PLG	041335	
Frame DN25/3xDN40 PLG	041337	

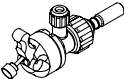
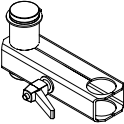
	Order no.	Image
Inlet valve, complete	041348	
Extension	041270	
	Order no.	
PTFE hose connection SVL 22	027338	
Seal PTFE	005155	
Tubing. PTFE, Ø8/10 mm, white, per m	027277	
Use: Vacuum, feeding (industrial Rotavapor®).		

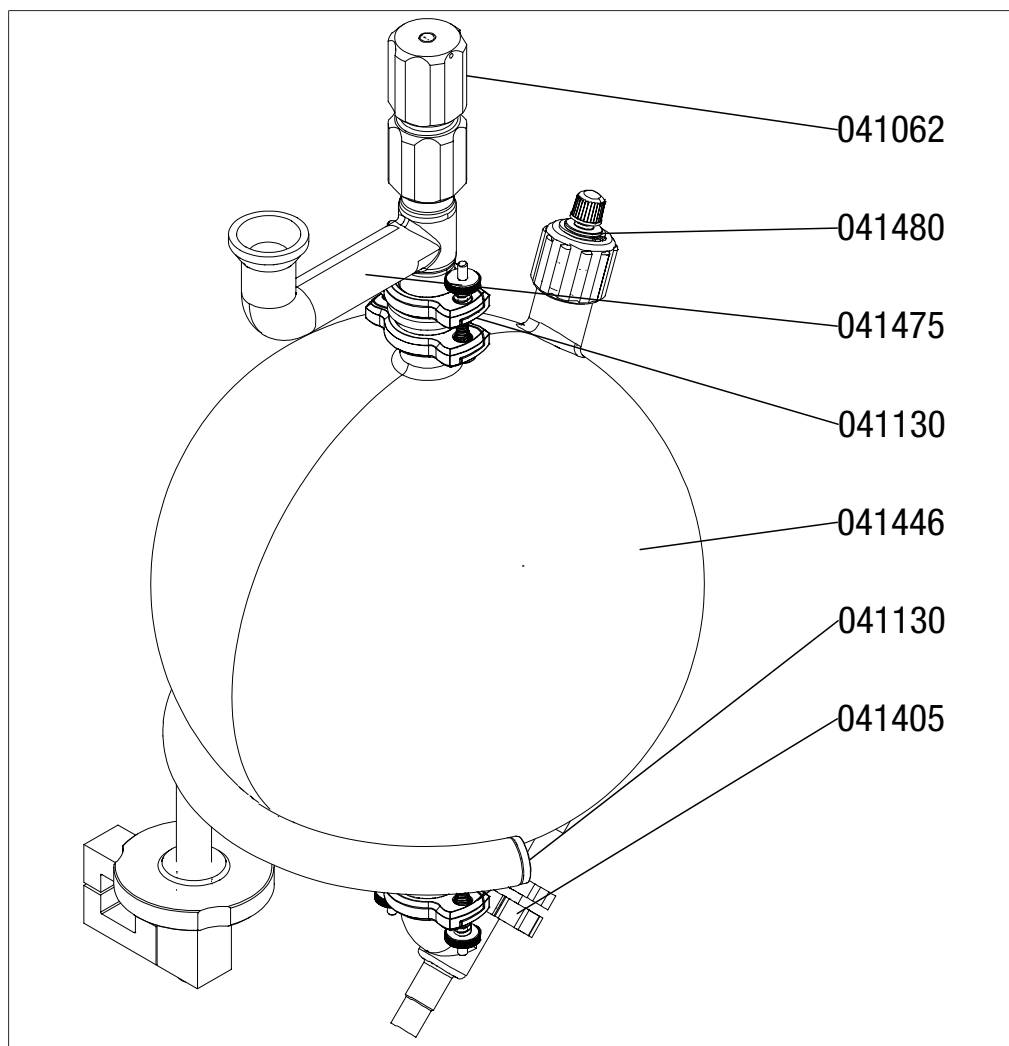

**Spare parts single receiver**

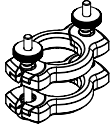
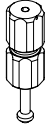
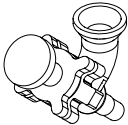
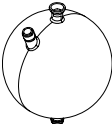
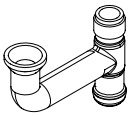
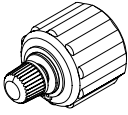

	<b>Order no.</b>	<b>Image</b>
EasyClamp, DN25	041130	
Industrial tap, small	041062	
Angle seat drain valve	041405	
Receiving flask 20 lt. PLG	041446	
Branching piece R-250 PLG	041475	
Ventilation duct, complete	041480	

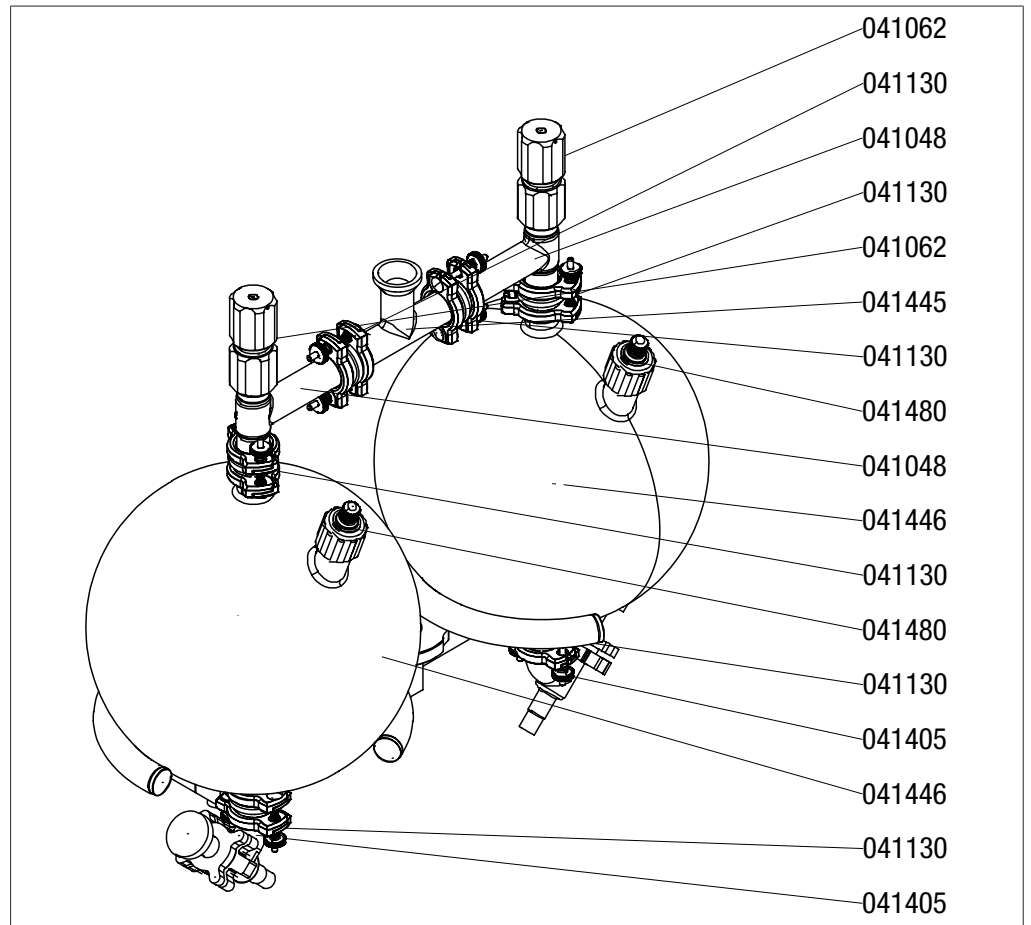

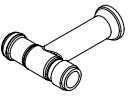
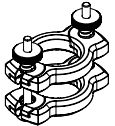
**Spare parts double receiver**

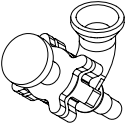
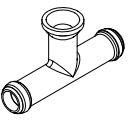

	<b>Order no.</b>	<b>Image</b>
Branching piece 1 PLG	041048	
EasyClamp, DN25	041130	
Industrial tap, small	041062	
Angle seat drain valve	041405	
T-piece DN 3x40 PLG	041445	

	<b>Order no.</b>	<b>Image</b>
Receiving flask 20 lt. PLG	041446	
Ventilation duct, complete	041480	

### 12.2.2 Further spare parts

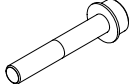
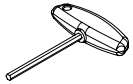
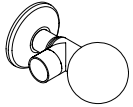
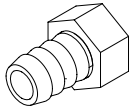
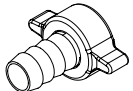
	<b>Order no.</b>	<b>Image</b>
O-ring 130x5.0 Fpm70	027378	
EasyClamp element, DN70	041135	
PTFE coated silicon gasket for DN25 (set of 5)	11056381	
PTFE coated silicone gasket for DN40 (set of 5)	11065382	
Set of 5 O-rings 64 x 5.0	041229	
Set of 5 SVL 15 seals	041946	
Snap flange coupling, complete	041415	
Screw cap	041416	
Tool	041472	
Cooling water tap, complete	003693	
Nipple 3/4" x 20 mm	003810	
Nipple 3/4" x 16 mm	041412	



	Order no.	Image
Reducer ½" x ¾"	041448	

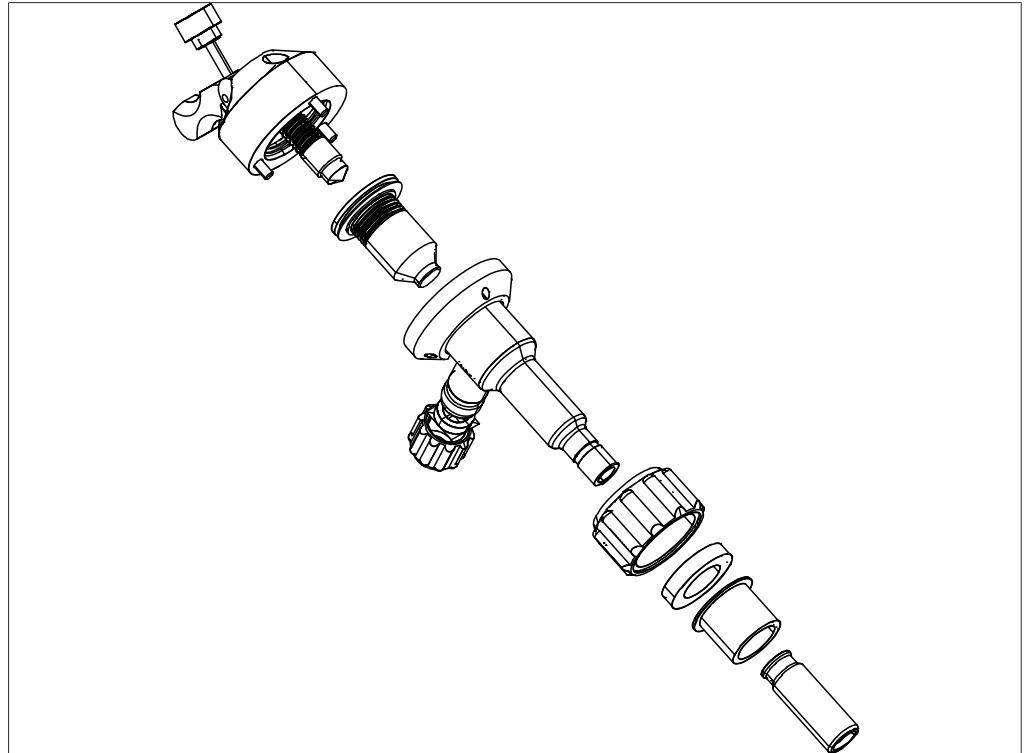

### 12.2.3 Inlet valve

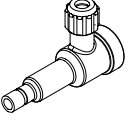
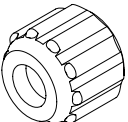
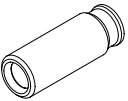

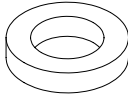
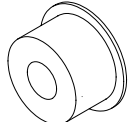
	Order no.	Image
PTFE bellow	041388	
Glass body	041346	
Set of 5 SVL 15 seals	041946	
Screw Cap SVL 15	003549	
Connection, PTFE	041354	

	Order no.	Image
Screw ring SVL 30	003223	
Seal SVL 30	000398	
Support ring inlet valve	041147	

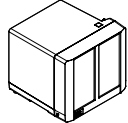
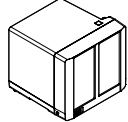
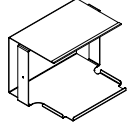
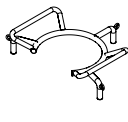
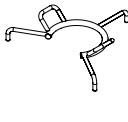
### 12.2.4 Accessories

	Order no.	Image
Vacuum Pump V-600 Chemically resistant 3-stage diaphragm pump. It impresses with its silent and economical operation. Capacity and final vacuum: 3.1 m <sup>3</sup> /h, 1.5 mbar	11V600800	
Vacuum Pump V-600 Chemically resistant 3-stage diaphragm pump. It impresses with its silent and economical operation. With secondary condenser. Capacity and final vacuum: 3.1 m <sup>3</sup> /h, 1.5 mbar	11V600810	
Holder vacuum pump	11071091	
Manual flask handler for 50 L flask For easy mounting and removal of the flasks along with safe transport	041414	
Manual flask handler for 20 L flask For easy mounting and removal of the flasks along with safe transport.	041410	
Flange adapter for flasks , SJ29.2/32 To use a 1, 2 or 3 L evaporating flask with SJ29.2/32	11058738	
Vacuum pump Sogevac SV40 Rotary vane pump with a flow rate of 40 m <sup>3</sup> /h and an ultimate vacuum of < 2 mbar.	034063	
Foam detector assembly Internal sensor detects rising foam and triggers a short aeration pulse, eliminating foam. Only in combination with a descending glass assembly.	11056083	

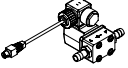
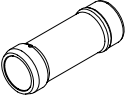
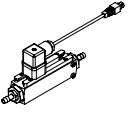
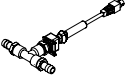
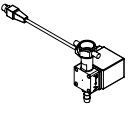
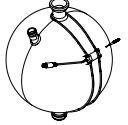
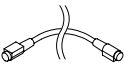
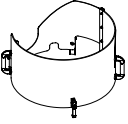
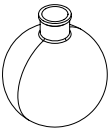
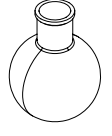
	Order no.	Image
Vacuum valve, 4 mm, 24 V, connection piece 12.5 mm Electrical valve for vacuum regulation when operated with a non-BUCHI vacuum pump.	11055928	
Vapor duct with integrated sinter plate The integrated sinter plate P3 protects the condenser assembly against powder and dust during the drying process.	041100	
Cooling water flow sensor Checks the flow of coolant, stopping operation when flow of coolant is insufficient or interrupted.	11055971	
Cooling water temperature sensor Needed to display the coolant temperature for optimal distillation settings.	11055988	
Cooling water valve Eliminates unnecessary water waste by stopping cooling water flow when not in use.	041191	
Level sensor for receiving flask For defined concentration of product or to prevent an overflow of the secondary condenser if combined with a Vacuum Pump V-600 with secondary condenser	11056192	
Stopper, PE, 120 mm To close the evaporating flask	11057349	
Communication cable. BUCHI COM, 15 m, 6p Enables connection between Rotavapor®, Interface, Vacuum Pump, Recirculating Chiller, VacuBox and LegacyBox.	11064090	
IQ/OQ R-250 Pro official BUCHI document	11071749	
Repeating OQ R-250 Pro	11071750	
Splash protection (cpl.)	041420	
Evaporating flask 50 L	041339	
Evaporating flask 20 L	041432	
Drying flask 20 ltr.	041393	

	Order no.	Image
Drying flask 50 ltr.	041394	
Flask crane	041494	
For the safely secured transport of a 50 liter flask. Incl. the 50 liter manual flask handler.		

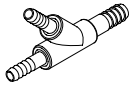

### 12.2.5 Hoses

	Order no.	Image
Softaflex, ID 19 mm	037617	
Y-piece, 12 mm / 16 mm	041473	

	Order no.
Tubing, PVC, 10/15 mm, transparent, per m Use: cooling tube to Rotavapor® R-220 Pro	027146
PVC hose, ID 14 mm	017383
Tubing. Nylflex, PVC-P, Ø8/14 mm, transparent, per m	004113
Tubing. PTFE, Ø8/10 mm, white, per m Use: Vacuum, feeding (industrial Rotavapor®).	027277
Tubing. Synthetic rubber, Ø6/13 mm, black, per m Use: Vacuum.	11063244

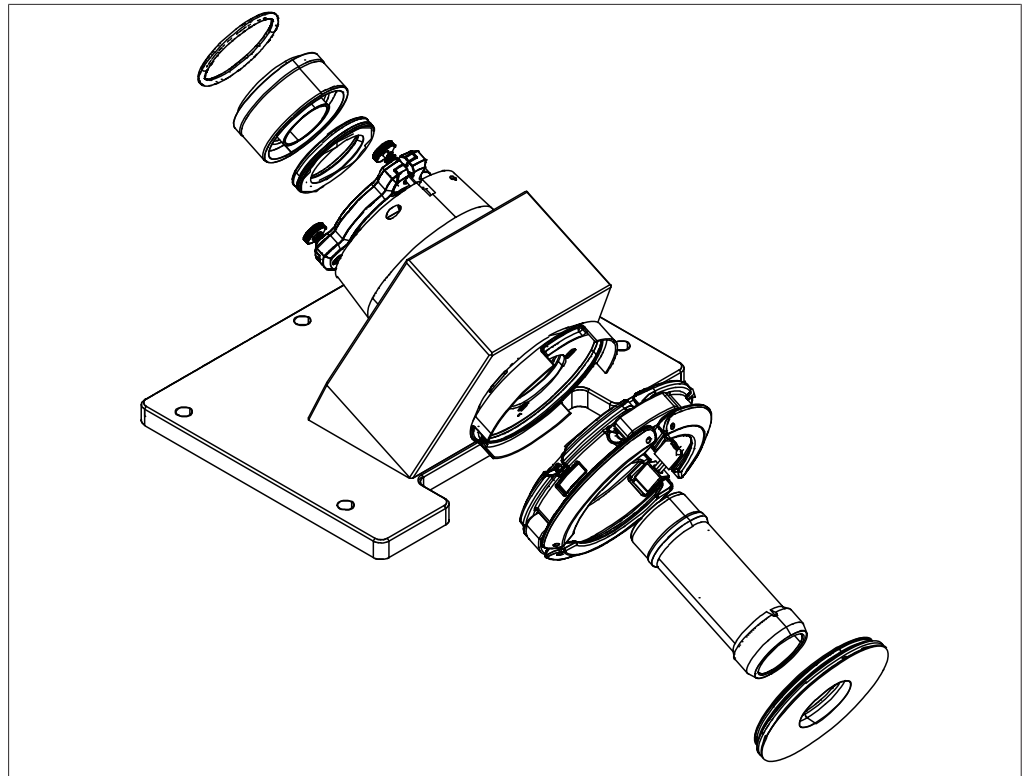
### 12.2.6 Gear box

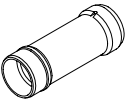
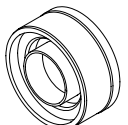

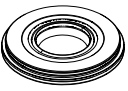
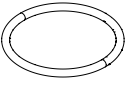
	Order no.	Image
Seal tool	020075	
Vapor duct	041084	
Seal holder	041094	
Vacuum seal	041095	
Evaporating flask seal, complete	041121	
Set of 5 distribution head sealings	041231	

## BUCHI Affiliates:

### Europe

#### Switzerland/Austria

**BÜCHI Labortechnik AG**  
CH – 9230 Flawil  
T +41 71 394 63 63  
F +41 71 394 64 64  
buchi@buchi.com  
www.buchi.com

#### Italy

**BUCHI Italia s.r.l.**  
IT – 20010 Cornaredo (MI)  
T +39 02 824 50 11  
F +39 02 575 12 855  
italia@buchi.com  
www.buchi.com/it-it

#### Benelux

**BÜCHI Labortechnik GmbH**  
Branch Office Benelux  
NL – 3342 GT Hendrik-Ido-Ambacht  
T +31 78 684 94 29  
F +31 78 684 94 30  
benelux@buchi.com  
www.buchi.com/bx-en

#### Russia

**BUCHI Russia/CIS**  
Russia 127287 Moscow  
T +7 495 36 36 495  
russia@buchi.com  
www.buchi.com/ru-ru

#### France

**BUCHI Sarl**  
FR – 91140 Villebon-sur-Yvette  
T +33 1 56 70 62 50  
F +33 1 46 86 00 31  
france@buchi.com  
www.buchi.com/fr-fr

#### Spain

**BUCHI Ibérica S.L.U.**  
ES – 08960 Barcelona  
T +34 936 06 8010  
iberica@buchi.com  
www.buchi.com/es-es

#### Germany

**BÜCHI Labortechnik GmbH**  
DE – 45127 Essen  
T +800 414 0 414 0 (Toll Free)  
T +49 201 747 49 0  
F +49 201 747 49 20  
deutschland@buchi.com  
www.buchi.com/de-de

#### United Kingdom

**BUCHI UK Ltd.**  
GB – Suffolk CB8 7SQ  
T +44 161 633 1000  
F +44 161 633 1007  
uk@buchi.com  
www.buchi.com/gb-en

### NIR-Online

#### Germany

**BÜCHI NIR-Online**  
DE – 69190 Walldorf  
T +49 6227 73 26 60  
F +49 6227 73 26 70  
nir-online@buchi.com  
www.nir-online.de

### America

#### Brazil

**BUCHI Brasil Ltda.**  
BR – Valinhos SP 13271-200  
T +55 19 3849 1201  
F +55 19 3849 2907  
brasil@buchi.com  
www.buchi.com/br-pt

#### USA/Canada

**BUCHI Corporation**  
US – New Castle, DE 19720  
T +1 877 692 8244 (Toll Free)  
T +1 302 652 3000  
F +1 302 652 8777  
us-sales@buchi.com  
www.buchi.com/us-en

### Asia

#### China

**BUCHI China**  
CN – 200233 Shanghai  
T +86 21 6280 3366  
F +86 21 5230 8821  
china@buchi.com  
www.buchi.com/cn-zh

#### India

**BUCHI India Private Ltd.**  
IN – Mumbai 400 055  
T +91 22 667 75400  
F +91 22 667 18986  
india@buchi.com  
www.buchi.com/in-en

#### Indonesia

**PT. BUCHI Indonesia**  
ID – Tangerang 15321  
T +62 21 537 62 16  
F +62 21 537 62 17  
indonesia@buchi.com  
www.buchi.com/id-in

#### Japan

**Nihon BUCHI K.K.**  
JP – Tokyo 110-0008  
T +81 3 3821 4777  
F +81 3 3821 4555  
nihon@buchi.com  
www.buchi.com/jp-ja

#### Korea

**BUCHI Korea Inc.**  
KR – Seoul 153-782  
T +82 2 6718 7500  
F +82 2 6718 7599  
korea@buchi.com  
www.buchi.com/kr-ko

#### Malaysia

**BUCHI Malaysia Sdn. Bhd.**  
MY – 47301 Petaling Jaya,  
Selangor  
T +60 3 7832 0310  
F +60 3 7832 0309  
malaysia@buchi.com  
www.buchi.com/my-en

#### Singapore

**BUCHI Singapore Pte. Ltd.**  
SG – Singapore 609919  
T +65 6565 1175  
F +65 6566 7047  
singapore@buchi.com  
www.buchi.com/sg-en

#### Thailand

**BUCHI (Thailand) Ltd.**  
TH – Bangkok 10600  
T +66 2 862 08 51  
F +66 2 862 08 54  
thailand@buchi.com  
www.buchi.com/th-th

## BUCHI Support Centers:

#### South East Asia

**BUCHI (Thailand) Ltd.**  
TH-Bangkok 10600  
T +66 2 862 08 51  
F +66 2 862 08 54  
bacc@buchi.com  
www.buchi.com/th-th

#### Middle East

**BÜCHI Labortechnik AG**  
UAE – Dubai  
T +971 4 313 2860  
F +971 4 313 2861  
middleeast@buchi.com  
www.buchi.com

#### Latin America

**BUCHI Latinoamérica S. de R.L. de C.V.**  
MX – Mexico City  
T +52 55 9001 5386  
latinoamerica@buchi.com  
www.buchi.com/es-es

We are represented by more than 100 distribution partners worldwide.  
Find your local representative at: [www.buchi.com](http://www.buchi.com)